



Agilent 75000 Series B

**Agilent E1343A, E1344A, E1345A, E1347A,
E1355A and E1356A
Relay Multiplexers**

Service Manual



Copyright © Agilent Technologies, Inc. 2005

Printed in Malaysia

Contents

E1343A/44A/45A/47A/55A/56A Service Manual

Warranty	3
Safety Symbols	4
WARNINGS	4
Declaration of Conformity	5
Reader Comment Sheet	7
Manual Overview	9
Manual Content	9
Chapter 1. General Information	11
Introduction	11
Safety Considerations	12
WARNINGS	12
CAUTIONS	13
Relay Life	14
Loading and Switching Frequency Effects	14
End-of-Life Detection	14
Replacement Strategy	15
Multiplexer Descriptions	15
E1343A/44A Descriptions	15
E1345A/47A Descriptions	15
E1355A/56A Descriptions	15
Multiplexer Specifications	16
Multiplexer Environment	16
Multiplexer Serial Numbers	16
Multiplexer Options	16
Schematics and Component Locators	16
Recommended Test Equipment	17
Inspection/Shipping	17
Initial Inspection	17
Shipping Guidelines	19
Chapter 2. Verification Tests	21
Introduction	21
Test Conditions & Procedures	21
Performance Test Record	21
Verification Test Examples	21
Functional Verification Test	22
Procedure	22
Example	22
Operation Verification Test	22
Performance Verification Tests	23
Wiring the Test Fixture	23
Performance Test Record	37
Test Limits	37
Measurement Uncertainty	37

Chapter 3. Replaceable Parts	41
Introduction	41
Replaceable Parts List	41
Parts Locators	46
Chapter 4. Service	49
Introduction	49
Equipment Required	49
Service Aids	49
E1343A/44A Multiplexer Descriptions	50
E1345A/47A Multiplexer Descriptions	51
E1355A/56A Strain Gage Multiplexer Descriptions	53
Troubleshooting Techniques	56
Identifying the Problem	56
Making Visual Checks	57
Testing the Multiplexer	58
Repair and Maintenance Guidelines	59
ESD Precautions	59
Soldering Printed Circuit Boards	59
Post-Repair Safety Checks	59
Component Locators and Schematic Diagrams	60
Appendix A. Verification Tests - C Programs	63
Example: Self-Test	63
Example: Closed Channel Resistance Test	64
Example: DC Isolation Test	68
Appendix B. Backdating Information	71
Introduction	71
Replaceable Parts List	71
Parts Locators	78

Certification

Agilent Technologies, Inc. certifies that this product met its published specifications at the time of shipment from the factory. Agilent Technologies further certifies that its calibration measurements are traceable to the United States National Institute of Standards and Technology (formerly National Bureau of Standards), to the extent allowed by that organization's calibration facility, and to the calibration facilities of other International Standards Organization members.

Warranty

This Agilent Technologies product is warranted against defects in materials and workmanship for a period of one year from date of shipment. Duration and conditions of warranty for this product may be superseded when the product is integrated into (becomes a part of) other Agilent products. During the warranty period, Agilent Technologies will, at its option, either repair or replace products which prove to be defective.

For warranty service or repair, this product must be returned to a service facility designated by Agilent Technologies. Buyer shall pre-pay shipping charges to Agilent and Agilent shall pay shipping charges to return the product to Buyer. However, Buyer shall pay all shipping charges, duties, and taxes for products returned to Agilent from another country.

Agilent warrants that its software and firmware designated by Agilent for use with a product will execute its programming instructions when properly installed on that product. Agilent does not warrant that the operation of the product, or software, or firmware will be uninterrupted or error free.

Limitation Of Warranty

The foregoing warranty shall not apply to defects resulting from improper or inadequate maintenance by Buyer, Buyer-supplied products or interfacing, unauthorized modification or misuse, operation outside of the environmental specifications for the product, or improper site preparation or maintenance.

The design and implementation of any circuit on this product is the sole responsibility of the Buyer. Agilent does not warrant the Buyer's circuitry or malfunctions of Agilent products that result from the Buyer's circuitry. In addition, Agilent does not warrant any damage that occurs as a result of the Buyer's circuit or any defects that result from Buyer-supplied products.

NO OTHER WARRANTY IS EXPRESSED OR IMPLIED. AGILENT TECHNOLOGIES SPECIFICALLY DISCLAIMS THE IMPLIED WARRANTIES OF MERCHANTABILITY AND FITNESS FOR A PARTICULAR PURPOSE.

Exclusive Remedies

THE REMEDIES PROVIDED HEREIN ARE BUYER'S SOLE AND EXCLUSIVE REMEDIES. AGILENT TECHNOLOGIES SHALL NOT BE LIABLE FOR ANY DIRECT, INDIRECT, SPECIAL, INCIDENTAL, OR CONSEQUENTIAL DAMAGES, WHETHER BASED ON CONTRACT, TORT, OR ANY OTHER LEGAL THEORY.

Notice

The information contained in this document is subject to change without notice. AGILENT TECHNOLOGIES MAKES NO WARRANTY OF ANY KIND WITH REGARD TO THIS MATERIAL, INCLUDING, BUT NOT LIMITED TO, THE IMPLIED WARRANTIES OF MERCHANTABILITY AND FITNESS FOR A PARTICULAR PURPOSE. Agilent shall not be liable for errors contained herein or for incidental or consequential damages in connection with the furnishing, performance or use of this material. This document contains proprietary information which is protected by copyright. All rights are reserved. No part of this document may be photocopied, reproduced, or translated to another language without the prior written consent of Agilent Technologies, Inc. Agilent assumes no responsibility for the use or reliability of its software on equipment that is not furnished by Agilent.

U.S. Government Restricted Rights

The Software and Documentation have been developed entirely at private expense. They are delivered and licensed as "commercial computer software" as defined in DFARS 252.227-7013 (Oct 1988), DFARS 252.211-7015 (May 1991) or DFARS 252.227-7014 (Jun 1995), as a "commercial item" as defined in FAR 2.101(a), or as "Restricted computer software" as defined in FAR 52.227-19 (Jun 1987) (or any equivalent agency regulation or contract clause), whichever is applicable. You have only those rights provided for such Software and Documentation by the applicable FAR or DFARS clause or the Agilent standard software agreement for the product involved.



Agilent Technologies

E1343A, E1344A, E1345A, E1347A, E1355A and E1356A Relay Multiplexers Service Manual
Edition 4

Copyright © 2005 Agilent Technologies, Inc. All Rights Reserved.

Documentation History

All Editions and Updates of this manual and their creation date are listed below. The first Edition of the manual is Edition 1. The Edition number increments by 1 whenever the manual is revised. Updates, which are issued between Editions, contain replacement pages to correct or add additional information to the current Edition of the manual. Whenever a new Edition is created, it will contain all of the Update information for the previous Edition. Each new Edition or Update also includes a revised copy of this documentation history page.

Edition 1 (Part Number E1345-90011) October 1993
Edition 2 (Part Number E1345-90012) June 1996
Edition 3 (Part Number E1345-90013) June 1997
Edition 4 (Part Number E1345-90013) September 2005

Safety Symbols



Instruction manual symbol affixed to product. Indicates that the user must refer to the manual for specific WARNING or CAUTION information to avoid personal injury or damage to the product.



Indicates the field wiring terminal that must be connected to earth ground before operating the equipment—protects against electrical shock in case of fault.

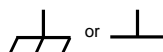

Frame or chassis ground terminal—typically connects to the equipment's metal frame.



Alternating current (AC).



Direct current (DC).



Indicates hazardous voltages.

WARNING

Calls attention to a procedure, practice, or condition that could cause bodily injury or death.

CAUTION

Calls attention to a procedure, practice, or condition that could possibly cause damage to equipment or permanent loss of data.

WARNINGS

The following general safety precautions must be observed during all phases of operation, service, and repair of this product. Failure to comply with these precautions or with specific warnings elsewhere in this manual violates safety standards of design, manufacture, and intended use of the product. Agilent Technologies, Inc. assumes no liability for the customer's failure to comply with these requirements.

Ground the equipment: For Safety Class 1 equipment (equipment having a protective earth terminal), an uninterruptible safety earth ground must be provided from the mains power source to the product input wiring terminals or supplied power cable.

DO NOT operate the product in an explosive atmosphere or in the presence of flammable gases or fumes.

For continued protection against fire, replace the line fuse(s) only with fuse(s) of the same voltage and current rating and type. DO NOT use repaired fuses or short-circuited fuse holders.

Keep away from live circuits: Operating personnel must not remove equipment covers or shields. Procedures involving the removal of covers or shields are for use by service-trained personnel only. Under certain conditions, dangerous voltages may exist even with the equipment switched off. To avoid dangerous electrical shock, DO NOT perform procedures involving cover or shield removal unless you are qualified to do so.

DO NOT operate damaged equipment: Whenever it is possible that the safety protection features built into this product have been impaired, either through physical damage, excessive moisture, or any other reason, REMOVE POWER and do not use the product until safe operation can be verified by service-trained personnel. If necessary, return the product to an Agilent Technologies Sales and Service Office for service and repair to ensure that safety features are maintained.

DO NOT service or adjust alone: Do not attempt internal service or adjustment unless another person, capable of rendering first aid and resuscitation, is present.

DO NOT substitute parts or modify equipment: Because of the danger of introducing additional hazards, do not install substitute parts or perform any unauthorized modification to the product. Return the product to an Agilent Technologies Sales and Service Office for service and repair to ensure that safety features are maintained.



Manufacturer's Name: Agilent Technologies, Incorporated
Manufacturer's Address: 815 – 14th St. SW
Loveland, Colorado 80537
USA

Declares, that the product

Product Name: 16 Channel Relay Multiplexer
Model Number: E1345A
Product Options: *This declaration covers all options of the above product(s).*

Conforms with the following European Directives:

The product herewith complies with the requirements of the Low Voltage Directive 73/23/EEC and the EMC Directive 89/336/EEC (including 93/68/EEC) and carries the CE Marking accordingly.

Conforms with the following product standards:

EMC	Standard	Limit
	CISPR 11:1990 / EN 55011:1991	Group 1 Class A
	EN50082-1 :1992	
	IEC 801-2 :1991	4kV CD, 8kV AD
	IEC 801-3 :1984	3 V/m
	IEC 801-4 :1988	0.5kV signal lines, 1kV power lines

The product was tested in a typical configuration with Agilent Technologies or Hewlett-Packard Company test systems

Safety
IEC 1010-1:1990+A2:1996 / EN 61010-1:1993
Canada: CSA C22.2 No. 1010.1:1992
UL 3111-1 : 1994

3 May 2001
Date

Ray Corson
Product Regulations Program Manager

For further information, please contact your local Agilent Technologies sales office, agent or distributor.
Authorized EU-representative: Agilent Technologies Deutschland GmbH, Herrenberger Strabe 130, D 71034 Böblingen, Germany

Notes

What's in This Manual

Manual Overview

This manual shows how to service the E1343A, E1344A, E1345A, E1347A, E1355A, and E1356A Relay Multiplexers. Consult the *E1343A/E1344A/E1345A/E1347A User's Manual* for additional information on installing, configuring, and operating the E1343A, E1344A, E1345A and E1347A. Consult the *E1355A/E1356A Strain Gage Multiplexer User's Manual* for additional information on installing, configuring, and operating the E1355A and E1356A. Consult the appropriate mainframe user's manual for information on configuring and operating the mainframe.

Manual Content

Chap	Title	Content
1	General Information	Provides a basic description and lists the test equipment required for service.
2	Verification Tests	Functional verification, operation verification, and performance verification tests.
3	Replaceable Parts	Lists replaceable parts for multiplexers as follows: E1343A w/Serial Number 3131A00852 and higher E1344A w/Serial Number 3131A00512 and higher E1345A w/Serial Number 2934A07622 and higher E1347A w/Serial Number 2934A03663 and higher E1355A w/Serial Number 3035A00331 and higher E1356A w/Serial Number 3035A00457 and higher.
4	Service	Procedures to aid in fault isolation and repair of the multiplexers.
Appx A	Verification Tests - C Programs	Provides C Program Examples to do the Verification Tests in Chapter 2.
Appx B	Backdating Information	Lists replaceable parts for multiplexers as follows: E1343A w/Serial Number 2934A00001 through 3131A00851 E1344A w/Serial Number 2934A00001 through 3131A00511 E1345A w/Serial Number 2934A00001 through 2934A07621 E1347A w/Serial Number 2934A00001 through 2934A03662 E1355A w/Serial Number 2934A00001 through 3035A00330 E1356A w/Serial Number 2934A00001 through 3035A00456 .

Introduction

This manual contains information required to test, troubleshoot, and repair the following Agilent relay multiplexers:

- E1343A 16-Channel High Voltage Relay Multiplexer
- E1344A 16-Channel High Voltage & Thermocouple Compensated Relay Multiplexer
- E1345A 16-Channel Relay Multiplexer
- E1347A 16-Channel Thermocouple Compensated Relay Multiplexer
- E1355A 8-Channel 120-Ohm Relay Multiplexer
- E1356A 8-Channel 350-Ohm Relay Multiplexer.

Refer to the respective module's User's Manual for information on programming and configuring these modules.

Figure 1-1 shows a typical layout for each of the relay multiplexers. Each multiplexer consists of a component assembly and a terminal module. The Agilent E1345A, E1347A, E1355A, and E1356A multiplexers use the same component assembly, but each multiplexer uses a unique terminal module. The Agilent E1343 and E1344 multiplexers use a different component assembly.

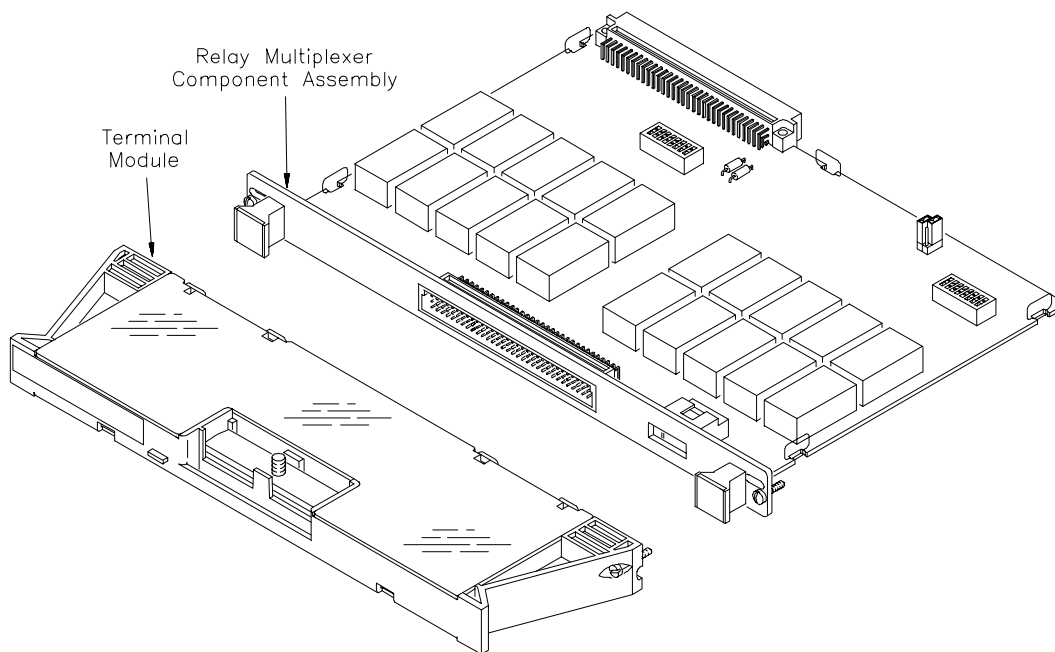

Figure 1-1. Relay Multiplexer Assemblies

Safety Considerations

These products are Safety Class I instruments provided with a protective earth terminal when installed in the mainframe. Check the mainframe, multiplexer, and all related documentation for safety markings and instructions before operation or service.

Refer to the WARNINGS on page 4 in this manual for a summary of safety information. Safety information for preventive maintenance, testing, and service follows and is also found throughout this manual.

WARNINGS

This section contains WARNINGS which must be followed for your protection when performing equipment maintenance or repair.

WARNING

SERVICE-TRAINED PERSONNEL ONLY. The information in this manual is for service-trained personnel who are familiar with electronic circuitry and are aware of the hazards involved. To avoid personal injury or damage to the instrument, do not perform procedures in this manual or do any servicing unless you are qualified to do so.

CHECK MAINFRAME POWER SETTINGS. Before applying power, verify that the mainframe setting matches the line voltage and that the correct fuse is installed. An uninterruptible safety earth ground must be provided from the main power source to the supplied power cord set.

GROUNDING REQUIREMENTS. Interruption of the protective (grounding) conductor (inside or outside the mainframe) or disconnecting the protective earth terminal will cause a potential shock hazard that could result in personal injury. (Grounding one conductor of a two-conductor outlet is not sufficient protection.)

IMPAIRED PROTECTION. Whenever it is likely that instrument protection has been impaired, the mainframe must be made inoperative and be secured against any unintended operation.

REMOVE POWER IF POSSIBLE. Some procedures in this manual may be performed with power supplied to the mainframe while protective covers are removed. Energy available at many points may, if contacted, result in personal injury. (If maintenance can be performed without power applied, the power should be removed.)

WARNING

USING AUTOTRANSFORMERS. If the mainframe is to be energized via an autotransformer (for voltage reduction) make sure the common terminal is connected to neutral (that is, the grounded side of the main's supply).

CAPACITOR VOLTAGES. Capacitors inside the mainframe may remain charged even when the mainframe has been disconnected from its source of supply.

USE PROPER FUSES. For continued protection against fire hazard, replace the line fuses only with fuses of the same current rating and type (such as normal blow, time delay, etc.). Do not use repaired fuses or short-circuited fuseholders.

WIRING INSULATION. To prevent electrical shock, all wires to the channel connections must be insulated to at least 120 V rms (170 V peak).

CAUTIONS

This section contains CAUTIONS which must be followed to avoid damage to the equipment when performing instrument maintenance or repair.

CAUTION

MAXIMUM VOLTAGE/CURRENT. The maximum voltage that may be applied between High (H), Low (L), and Guard (G) terminals is 170VDC or 120Vrms (170Vpeak) for the E1345A, E1347A, E1355A, and E1356A modules. The maximum voltage that may be applied between High (H), Low (L), and Guard (G) terminals is 250VDC or ACrms (354Vpeak) for the E1343A or E1344A. The maximum current is 50 mA (non-conductive) per channel. The maximum power per channel is 1 VA.

STATIC ELECTRICITY. Static electricity is a major cause of component failure. To prevent damage to the electrical components in the multiplexers, observe anti-static techniques whenever working on a multiplexer.

Relay Life

Electromagnetic relays are subject to normal wear-out. Relay life depends on several factors. Two factors are loading and switching frequency effects.

Loading and Switching Frequency Effects

Relay Load. In general, higher power switching reduces relay life. In addition, capacitive/inductive loads and high inrush currents (e.g., when turning on a lamp or motor) reduce relay life. *Exceeding the specified maximum inputs can cause catastrophic failure.*

Switching Frequency. Relay contacts heat up when switched. As the switching frequency increases, the contacts have less time to dissipate heat. The resulting increase in contact temperature reduces relay life.

End-of-Life Detection

A preventive maintenance routine can prevent problems caused by unexpected relay failure. The end-of-the life of a relay can be determined using one or more of the following methods. The best method (or combination of methods), as well as the failure criteria, depends on the application in which the relay is used.

Check Contact Resistance. As a relay begins to wear out, its contact resistance will increase. When the resistance exceeds a pre-determined value, the relay should be replaced. Typically, a relay should be replaced when the contact resistance exceeds 2.0Ω .

Check Stability of Contact Resistance. The stability of relay contact resistance decreases with age. Using this method, the contact resistance is measured several (5-10) times, and the variance of the measurements is determined. An increase in the variance indicates deteriorating performance.

Replace Relays after Defined Number of Operations. Relays can be replaced after a predetermined number of contact closures. However, this method requires knowledge of the applied load and life specifications for the applied load. For the multiplexers, maximum relay life is specified to be 10^8 operations at no load or 10^7 operations at rated load.

Replacement Strategy

The replacement strategy also depends on the application. If some relays are used more often, or at higher load, than the others, the relays can be individually replaced as needed. If all of the relays see similar loads and switching frequencies, then replace the entire circuit board when the relay end-of-life approaches. The sensitivity of the application should be weighed against the cost of replacing relays with some useful life remaining.

NOTE

Relays that wear out normally or fail due to misuse should not be considered defective and are not covered by the product's warranty.

Multiplexer Descriptions

The relay multiplexers are "instruments" in the slots of a VXIbus mainframe. As such, a multiplexer is assigned an error queue, input and output buffers, and a status register.

NOTE

Instruments are based on the logical addresses of the plug-in modules. Refer to the configuration guide provided with your system for information on setting the addresses to create an instrument.

E1343A/44A Descriptions

Both modules provide sixteen 3-wire or eight 4-wire multiplexer channels and can switch voltages up to 250VDC or VACrms. The E1344A provides a thermistor reference junction on the terminal card for thermocouple measurements. Both modules use the E1343A relay component module but they have different terminal card assemblies.

E1345A/47A Descriptions

The E1345A and E1347A multiplexers provide multiplexing for up to 16 channels (channels 00 through 15). Each channel has HIGH (H), LOW (L), and GUARD (G) connections. The two multiplexers are identical, except that the E1347A terminal card assembly adds a thermistor for temperature measurement applications.

E1355A/56A Descriptions

The E1355A and E1356A strain gage multiplexers (when used with a multimeter) provide static and dynamic strain measurement capabilities. Each multiplexer provides switching (multiplexing) for up to 8 channels (channels 00 through 07). Each channel has HIGH (H), LOW (L), GUARD (G), +E, -E1, and -E2 connections. The two multiplexers are identical, except that the E1355A uses 120Ω bridge resistors, and the E1356A uses 350Ω bridge resistors.

Multiplexer Specifications

Refer to the individual module's User's Manual for specifications. These specifications are the performance standards or limits against which the instrument may be tested.

Multiplexer Environment

The recommended operating environment for the relay multiplexers is:

Environment	Temperature	Humidity
Operating	0°C to +55°C	<65% relative (0°C to +40°C)
Storage and Shipment	-40°C to +75°C	<65% relative (0°C to +40°C)

Multiplexer Serial Numbers

Multiplexers covered by this manual are identified by a serial number prefix listed on the title page. The serial number plate is located on the backplane connector. If the serial number prefix of your instrument is greater than the one listed on the title page, a Manual Update (as required) will explain how to adapt this manual to your instrument.

Multiplexer Options

There are no electrical or mechanical options available for the E1343A, E1344A, E1345A, E1347A, E1355A, E1356A Relay Multiplexers.

Schematics and Component Locators

Component locators and schematics for the multiplexers are packaged with this manual. Most of them are located in the back of this manual in plastic sleeves for convenient storage. Refer to the tables at the end of Chapter 4 for a listing of what is included and where to find it.

Recommended Test Equipment

Table 1-1 lists the test equipment recommended for testing, adjusting, and servicing the relay multiplexers. Essential requirements for each piece of test equipment are described in the Requirements column.

Table 1-1. Recommended Test Equipment

Instrument	Requirements	Recommended Model	Use*
Controller, HP-IB	HP-IB compatibility as defined by IEEE Standard 488-1987 and the identical ANSI Standard MC1.1: SH1, AH1, T2, TE0, L2, LE0, SR0, RL0, PP0, DC0, DT0, and C1, 2, 3, 4, 5.	HP 9000 Series 300 or IBM compatible PC with BASIC	F,O,P,T
Mainframe	Compatible with multiplexer	E1300A, E1301A, E1302A or E1401B/T, E1421B (requires E1406A)	F,O,P,T
Digital Multimeter	2-wire ohms (up to 1 GΩ) 4-wire ohms	3458A or 34401A	O,P,T

* F = Functional Verification, O = Operation Verification Tests, P = Performance Verification Tests, T = Troubleshooting

Inspection/Shipping

This section contains initial (incoming) inspection and shipping guidelines for the multiplexers.

Initial Inspection

Use the steps in Figure 1-2 as guidelines to perform initial inspection of a relay multiplexer. Performance Verification tests are optional.

WARNING

To avoid possible hazardous electrical shock, do not perform electrical tests if there are signs of shipping damage to the shipping container or to the instrument.

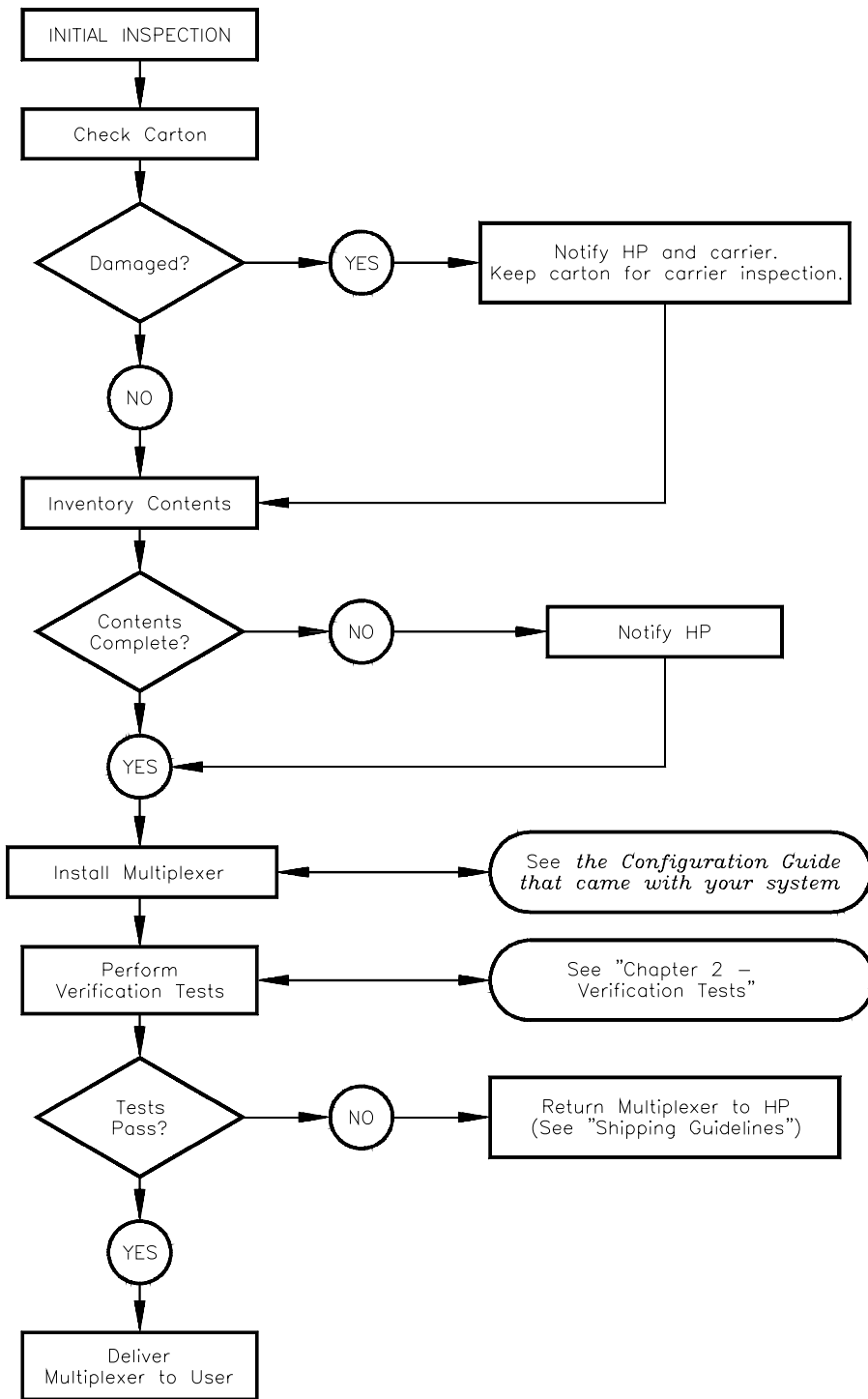
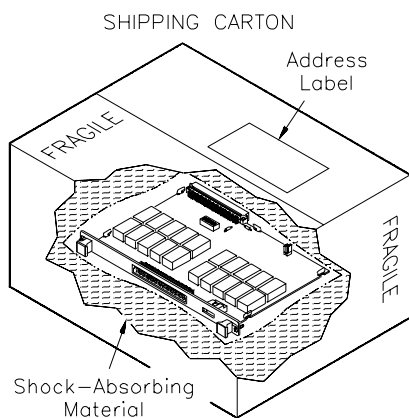

Figure 1-2. Initial (Incoming) Inspection Guidelines

Shipping Guidelines

Follow the steps in Figure 1-3 to return a relay multiplexer to an Agilent Technologies Sales and Service Office.



- * We recommend that you use the same shipping materials as those used in factory packaging (available from Agilent Technologies). For other (commercially-available) shipping materials, use a double-wall carton with minimum 2.4 MPa (350 psi) test.

Figure 1-3. Packaging/Shipping Guidelines

Introduction

This chapter describes the verification tests for the E1343A, E1344A, E1345A, E1347A, E1355A, E1356A Relay Multiplexers. The three levels of test procedures described in this chapter are used to verify that the modules:

- are functional (Functional Verification Test)
- meet selected testable specifications (Operation Verification)
- meet all testable specifications (Performance Verification)

Test Conditions & Procedures

See Table 1-1 for test equipment requirements. You should complete the Performance Verification tests at least once a year. For heavy use or severe operating environments, perform the tests more often. The verification tests assume that the person performing the tests understands how to operate the mainframe, the multiplexers, and the specified test equipment. The test procedures do not specify equipment settings for test equipment except in general terms. It is assumed that a qualified, service-trained technician will select and connect the cables, adapters, and probes required for the test.

Performance Test Record

The results of each Performance Verification test may be recorded in Table 2-2, "Performance Test Record," at the end of this chapter. You may photocopy this form, if desired.

Verification Test Examples

Each verification test procedure includes an example program that performs the test. All example programs assume the following configuration:

- HP 9000 Series 200/300 computer
- HP BASIC programming language
- Multiplexer address 70914
- Multiplexer card number 1
- 3458A Digital Multimeter (DMM)

Functional Verification Test

The Functional Verification Test for the multiplexer modules consists of sending the *IDN? command and checking the response. This test can be used to verify that the multiplexer is connected properly and is responding to a basic command.

Procedure

1. Verify that the multiplexer is properly installed in mainframe
2. Verify that the mainframe has passed its power-on test.
3. Send *IDN? to the multiplexer (see example following)
4. The return should be as follows (revision number may vary):

```
HEWLETT-PACKARD, SWITCHBOX, 0, A.06.00
```

NOTE

If the primary address setting, secondary address setting, or the interface select code is set incorrectly, the multiplexer will not respond. Verify proper address selection before troubleshooting.

Example

An example follows which uses an HP 9000 Series 300 computer with HP BASIC and a multiplexer address of 70914.

```
10 DIM A$(100)
20 OUTPUT 70914;"*IDN?"           !Send the ID query command
30 ENTER 70914;A$                 !Get response
40 PRINT A$                       !Print response
50 END
```

Operation Verification Test

The procedures in this section are used to provide a high level of confidence that the multiplexer is meeting published specifications. The Operation Verification Test is a subset of the Performance Verification Tests and is suitable for checkout after performing repairs.

The Operation Verification Test is performed by completing the Closed Channel Resistance Test (Test 2-1) as described in the Performance Verification Test procedures. This test is usually sufficient to verify that the multiplexer is meeting its specifications.

Performance Verification Tests

The procedures in this section are used to test the multiplexer's electrical performance using the specifications as the performance standards.

There are two performance verification tests for the relay multiplexers: Test 2-1: Closed-Channel Resistance Test, and Test 2-2: DC Isolation Test. These tests are suitable for incoming inspection, troubleshooting, and preventive maintenance.

Wiring the Test Fixture

A test fixture is required for the Performance Verification Tests. Figure 2-1 shows typical connections using a terminal module (aka "terminal block") for the test fixture. You may want to order an extra terminal module to use as a test fixture so that you don't have to re-wire each time the tests are performed. The E1345A terminal module may be used to test the E1343A/45A/55A and 56A. The terminal module part number is E1345-80001. The E1347A terminal module may be used to test the E1344A and 47A. The terminal module part number is E1347-80001.

However, in most cases the E1345-80001 is adequate for testing any or all of the relay multiplexer component modules.

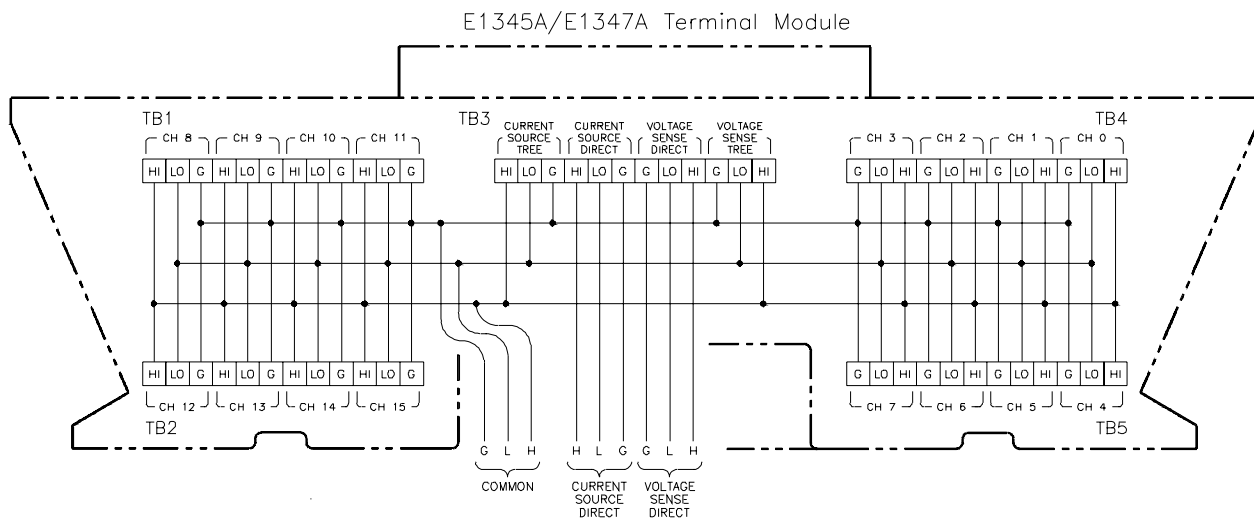

Figure 2-1. Typical Test Fixture Connections

Test 2-1: Closed Channel Resistance Test

This test verifies that all relay contacts meet the closed-channel resistance specification for the multiplexer. If the closed-channel resistance of any relay contact is greater than 2Ω , the relay should be replaced. This test uses the test fixture (see Figure 2-1).

Measuring Protection Resistors

Since there are 100Ω protection resistors (R20 through R31) in the relay paths, measure the protection resistor values to begin this test. The values of the protection resistors are then subtracted from the measured path resistance to determine the relay contact resistance. To measure the protection resistor values, set the 3458A DMM to 4-wire ohms, autorange and measure each resistor value with the DMM (see Figure 2-2). Record the measured values in Table 2-1.

NOTE

On the E1343A and E1344A, Resistors R22, R25, R28, and R31 are $1.0k\Omega$ resistors.

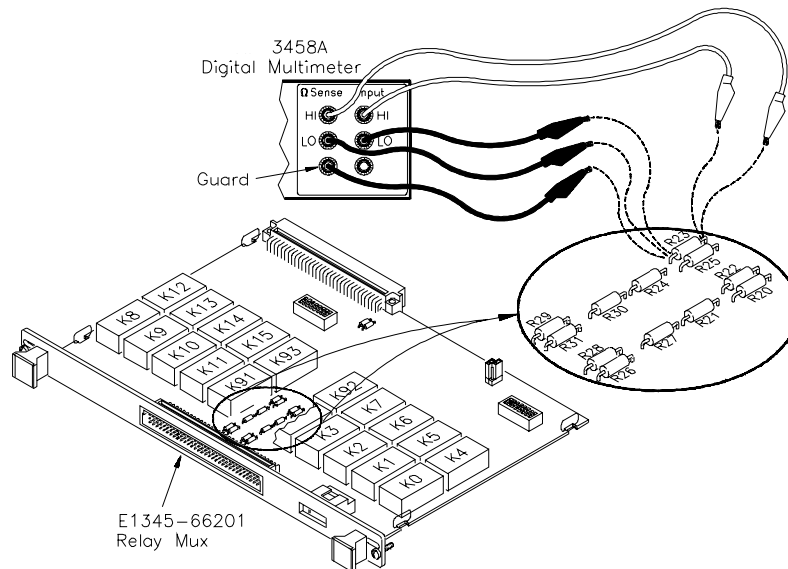

Figure 2-2. Typical Resistance Measurement Connections

Table 2-1. Measured Protection Resistor Values

Resistor	Measured Value (Ω)	Resistor	Measured Value (Ω)
R20	_____	R26	_____
R21	_____	R27	_____
R22	_____	R28	_____
R23	_____	R29	_____
R24	_____	R30	_____
R25	_____	R31	_____

Chs 00 - 07 and 90 HI Measurements

1. Make Hardware Connections

- Turn mainframe power OFF
- Connect DMM leads as shown in Figure 2-3
- Turn mainframe power ON

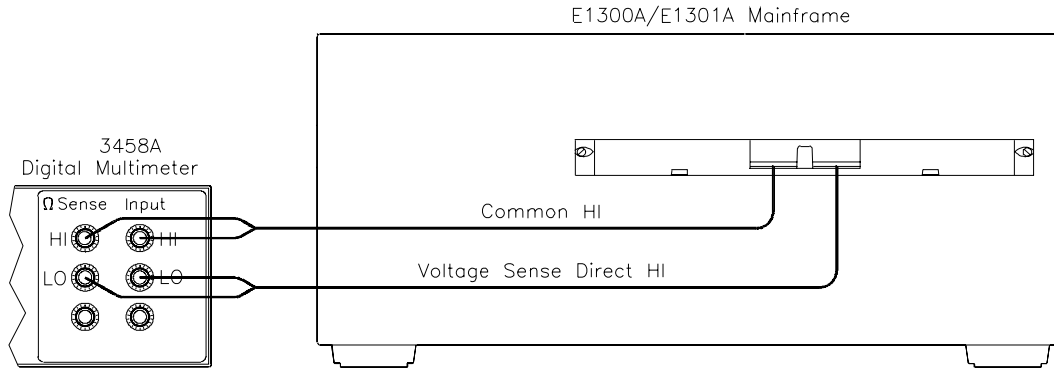

Figure 2-3. Ch 0-7 and 90 HI Measurements Connections

2. Measure Channel 00 HI Resistance

- Send *RST to multiplexer
- Send CLOS (@nn00) to close chan 00, where nn = card #
- Trigger the DMM with TRIG SGL and note reading
- Send OPEN (@nn00) to open channel 00
- Subtract measured value of R20 from DMM reading
- Enter the result in Table 2-2 for Channel 00 HI

3. Repeat for Channels 01 - 07 HI and Channel 90 HI

- Repeat steps 1 and 2 for channels 01 - 07 HI and 90 HI
- Use CLOS (@nncc) and OPEN (@nncc), where nn = card # and cc = channel # (omit leading zeroes in nn)
- For Channel 90 HI, subtract combined value of R20 + R26

Ch 00 - 07 and 90 LO Measurements

1. Make Hardware Connections

- Turn mainframe power OFF
- Connect DMM leads as shown in Figure 2-4
- Turn mainframe power ON

2. Measure Channel 00 LO Resistance

- Send *RST to multiplexer
- Send CLOS (@nn00) to close chan 00, where nn = card #
- Trigger the DMM with TRIG SGL and note reading
- Send OPEN (@nn00) to open channel 00
- Subtract measured value of R21 from DMM reading
- Enter the result in Table 2-2 for Channel 00 LO

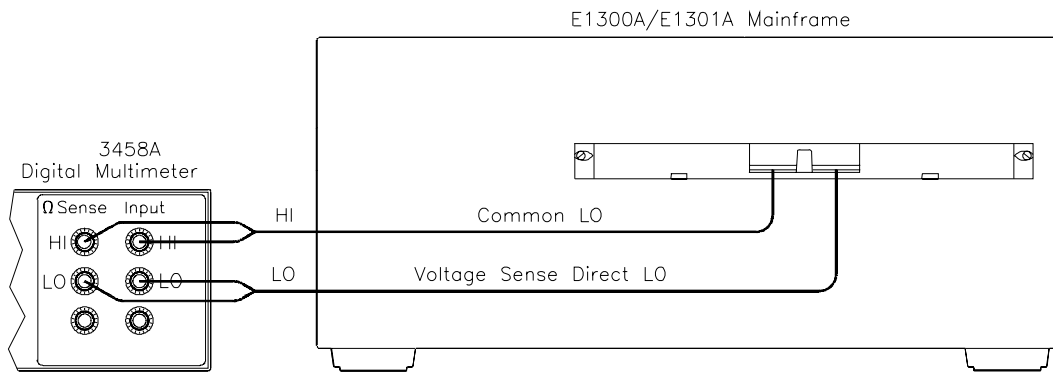

Figure 2-4. Ch 0-7 and 90 LO Measurement Connections

3. Repeat for Channels 01 - 07 LO and Channel 90 LO

- Repeat steps 1 and 2 for channels 01 - 07 LO and 90 LO
- Use CLOS (@nncc) and OPEN (@nncc), where nn = card # and cc = channel # (omit leading zeroes in nn)
- For Channel 90 LO, subtract combined value of R21 + R27

**Ch 00 - 07 and 90
GU Measurements**

1. Make Hardware Connections

- Turn mainframe power OFF
- Connect DMM leads as shown in Figure 2-5
- Turn mainframe power ON

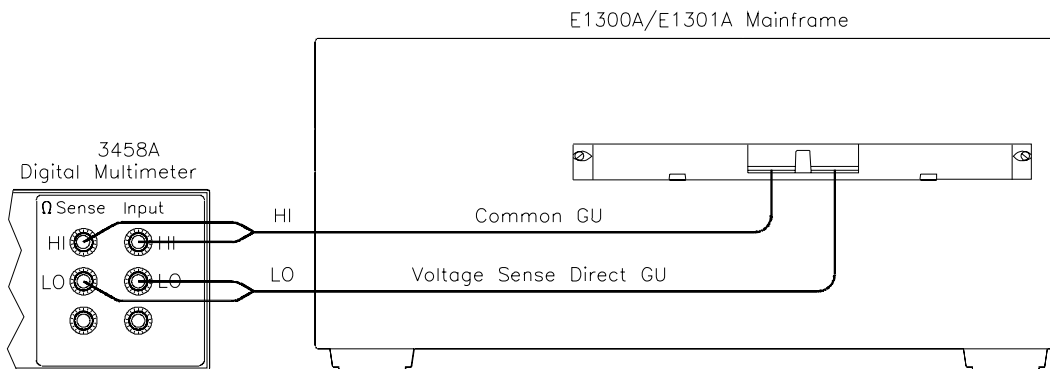

Figure 2-5. Ch 00-07 and 90 GU Measurements Connections

2. Measure Channel 00 GU Resistance

- Send *RST to multiplexer
- Send CLOS (@nn00) to close chan 00, where nn = card #
- Trigger the DMM with TRIG SGL and note reading
- Send OPEN (@nn00) to open channel 00
- Subtract measured value of R22 from DMM reading
- Enter the result in Table 2-2 for Channel 00 GU

3. Repeat for Channels 01 - 07 GU and Channel 90 GU

- Repeat steps 1 and 2 for channels 01 - 07 GU and 90 GU
- Use CLOS (@nncc) and OPEN (@nncc), where nn = card # and cc = channel # (omit leading zeroes in nn)
- For Channel 90 GU, subtract combined value of R22 + R28

Ch 08 - 15 and 91 - 92 HI Measurements

1. Make Hardware Connections

- Turn mainframe power OFF
- Connect DMM leads as shown in Figure 2-6
- Turn mainframe power ON

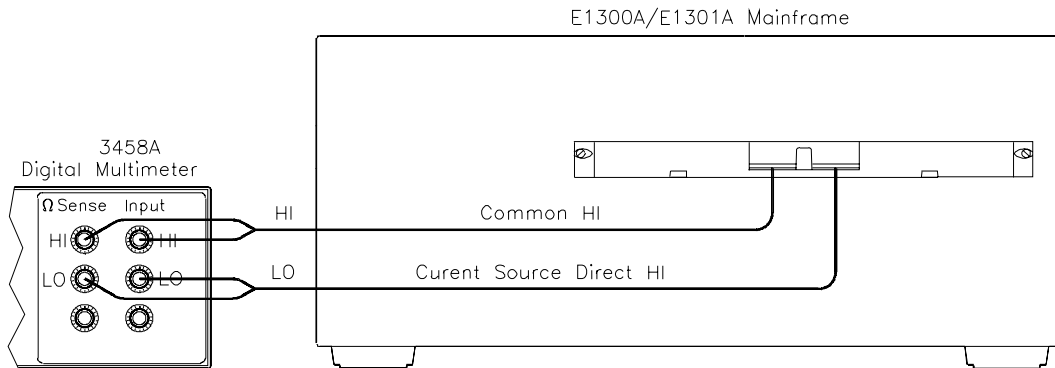

Figure 2-6. Ch 08-15 and 91-92 HI Measurements Connections

2. Measure Channel 08 HI Resistance

- Send *RST to multiplexer
- Send CLOS (@nn08) to close chan 08, where nn = card #
- Trigger the DMM with TRIG SGL and note reading
- Send OPEN (@nn08) to open channel 08
- Subtract measured value of R23 from DMM reading
- Enter the result in Table 2-2 for Channel 08 HI

3. Repeat for Channels 09 - 15 HI and Channels 91-92 HI

- Repeat steps 1 and 2 for channels 09 - 15 HI and 91 - 92 HI
- Use CLOS (@nncc) and OPEN (@nncc), where nn = card # and cc = channel # (omit leading zeroes in nn)
- For Channel 91 HI, subtract combined value of R23 + R29
- For Channel 92 HI, subtract combined value of R23 + R26

Ch 08 - 15 and 91 - 92 LO Measurements

1. Make Hardware Connections

- Turn mainframe power OFF
- Connect DMM leads as shown in Figure 2-7
- Turn mainframe power ON

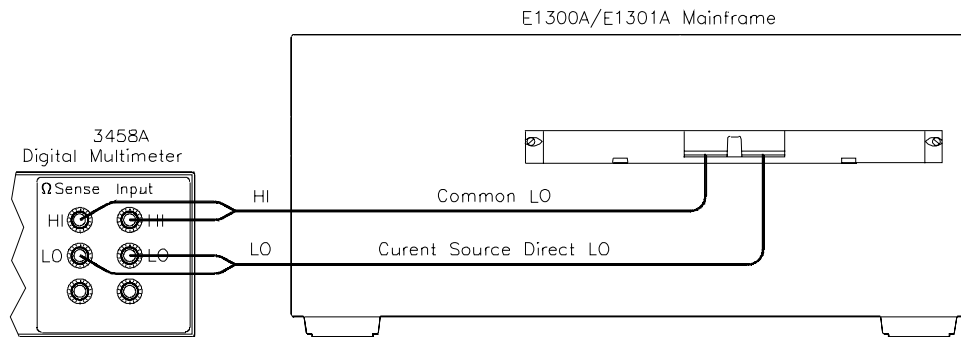

Figure 2-7. Chs 08-15 and 91-92 LO Measurements Connections

2. Measure Channel 08 LO Resistance

- Send *RST to multiplexer
- Send CLOS (@nn08) to close chan 08, where nn = card #
- Trigger the DMM with TRIG SGL and note reading
- Send OPEN (@nn08) to open channel 08
- Subtract measured value of R24 from DMM reading
- Enter the result in Table 2-2 for Channel 08 LO

3. Repeat for Channels 09 - 15 LO and Channels 91 - 92 LO

- Repeat steps 1 and 2 for channels 09 - 15 LO and 91 - 92 LO
- Use CLOS (@nncc) and OPEN (@nncc), where nn = card # and cc = channel # (omit leading zeroes in nn)
- For Channel 91 LO, subtract combined value of R24 + R30
- For Channel 92 LO, subtract combined value of R24 + R27

**Ch 08 - 15 and 91 - 92
GU Measurements**

1. Make Hardware Connections

- Turn mainframe power OFF
- Connect DMM leads as shown in Figure 2-8
- Turn mainframe power ON

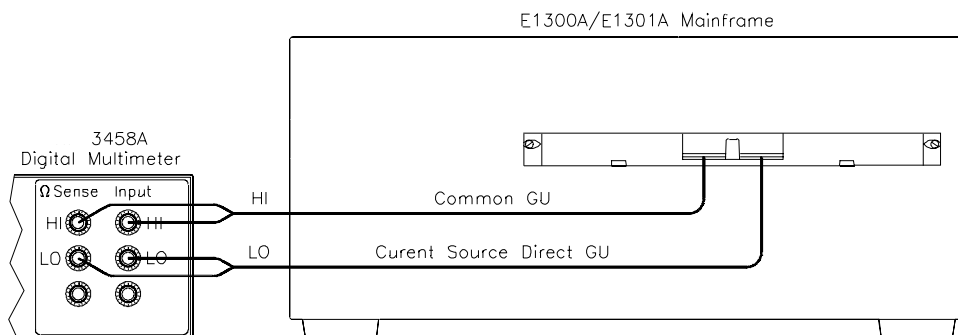

Figure 2-8. Chs 08-15 and 91-92 GU Measurements Connections

2. Measure Channel 08 GU Resistance

- Send *RST to multiplexer
- Send CLOS (@nn08) to close chan 08, where nn = card #
- Trigger the DMM with TRIG SGL and note reading
- Send OPEN (@nn08) to open channel 08
- Subtract measured value of R25 from DMM reading
- Enter the result in Table 2-2 for Channel 08 GU

3. Repeat for Channels 09 - 15 GU and Channels 91 - 92 GU

- Repeat steps 1 and 2 for channels 09 - 15 GU and 91- 92 GU
- Use CLOS (@nncc) and OPEN (@nncc), where nn = card # and cc = channel # (omit leading zeroes in nn)
- For Channel 91 GU, subtract combined value of R25 + R31
- For Channel 92 GU, subtract combined value of R25 + R28

Example: Closed Channel Resistance Test

The following program performs a Closed Channel Resistance Test on Channels 00 - 15 and 90 - 92 HI, LO, and GU. If the contact resistance for a channel is $>2.0 \Omega$, the program displays the message "Resistance for Channel *chan* Relay is >2.0 Ohms" and stops.

NOTE

Since small measurement variations occur when measuring the protection resistors, the program returns "0.00" if the calculated resistance is $<0 \Omega$.

```
10 ! RE-SAVE "CLOS_TEST"
20 ASSIGN @Dmm TO 722
30 ASSIGN @Mux TO 70914
40 DISP CHR$(129)
50 DIM R(20:31),Value0(8,2),Value1(9,2),Result0(8,2), Result1(9,2),
Path$(2)[2]
60 DATA HI,LO,GU
70 READ Path$(*)
80 !
90                                     !Measure protection resistors
100 !
110 PRINT "Measure Protection Resistors R20 - R31 "
120 PRINT TABXY(1,3)," 1. Turn mainframe power OFF"
130 PRINT TABXY(1,4)," 2. Remove E1345A Component Assembly
from mainframe"
140 PRINT TABXY(1,5)," 3. Set DMM for 4-wire ohms (OHMF) function
"
150 DISP " Press Continue when ready to measure protection resistors "
160 PAUSE
170 CLEAR SCREEN
180 FOR I=20 TO 31
190 PRINT TABXY(1,4),"Connect DMM leads (4-wire) to resistor R";I
```

Continued on Next Page

```

200 PRINT TABXY(1,5),"Measure resistor R";I;"value (in Ohms)"
210 INPUT " Enter resistor value (in Ohms), then press Continue ",R(I)
220 NEXT I
230 CLEAR SCREEN
240 PRINT "Install Component Assembly and Test Fixture "
250 PRINT
260 PRINT " 1. Turn Mainframe power OFF"
270 PRINT " 2. Install E1345A Component Assembly into Mainframe "
280 PRINT " 3. Attach Test Fixture to Component Assembly"
290 PRINT " 4. Turn Mainframe power ON "
300 PRINT " 5. Press Continue when ready to begin testing "
310 PAUSE
320 CLEAR SCREEN
330 !
340           ! Measure Channels 00-07 and Channel 90 (HI, LO, and GU)
350 !
360 OUTPUT @Dmm;"PRESET NORM;FUNC OHMF"
370 OUTPUT @Mux;"*RST"
380 FOR K=0 TO 2
390 PRINT TABXY(1,1),"Channel 00-07 and Channel 90 ";Path$(K);"
Measurements
400 PRINT TABXY(1,3),"Connect DMM Sense and Input HI leads to
COMMON ";Path$(K)
410 PRINT TABXY(1,4),"Connect DMM Sense and Input LO leads to
VOLTAGE SENSE ";Path$(K)
420 DISP " Press Continue when connections are complete "
430 PAUSE
440 CLEAR SCREEN
450 FOR I=0 TO 8
460 IF I<8 THEN J=I+100
470 IF I=8 THEN J=190
480 OUTPUT @Mux;"CLOS (@"&VAL$(J)&")"
490 OUTPUT @Dmm;"TRIG SGL"
500 ENTER @Dmm;Value0(I,K)
510 OUTPUT @Mux;"OPEN (@"&VAL$(J)&")"
520 IF I<8 AND K=0 THEN Result0(I,K)=Value0(I,K)-R(20)
530 IF I<8 AND K=1 THEN Result0(I,K)=Value0(I,K)-R(21)
540 IF I<8 AND K=2 THEN Result0(I,K)=Value0(I,K)-R(22)
550 IF I=8 AND K=0 THEN Result0(I,K)=Value0(I,K)-(R(20)+R(26))
560 IF I=8 AND K=1 THEN Result0(I,K)=Value0(I,K)-(R(21)+R(27))
570 IF I=8 AND K=2 THEN Result0(I,K)=Value0(I,K)-(R(22)+R(28))
580 IF Result0(I,K)<0. THEN Result0(I,K)=0.
590 IF Result0(I,K)>2.0 THEN

```

Continued on Next Page

```

600     PRINT "Resistance for Channel";I;"Relay is >2.0 Ohms"
610     PAUSE
620     END IF
630     NEXT I
640     IF K<2 THEN
650     PRINT "Measurements complete for Channels 00 - 07 and 90
";Path$(K)
660     DISP " Press Continue for Channels 00 - 07 and 90 ";Path$(K+1);"
measurements "
670     PAUSE
680     ELSE
690     PRINT " Measurements complete for Channels 00 - 07 and 90
";Path$(K)
700     DISP " Press Continue for Channels 08 - 15 and 91-92 tests "
710     PAUSE
720     END IF
730     NEXT K
740     !
750     !Measure Channels 08-15 and Channels 91-92 (HI, LO, and GU)
760     !
770     OUTPUT @Mux;"*RST"
780     CLEAR SCREEN
790     FOR K=0 TO 2
800     PRINT TABXY(1,1),"Channels 08-15 and Channels 91-92
";Path$(K);" Measurements "
810     PRINT TABXY(1,3),"Connect DMM Sense and Input HI leads to
COMMON ";Path$(K)
820     PRINT TABXY(1,4),"Connect DMM Sense and Input LO leads to
CURRENT SOURCE ";Path$(K)
830     DISP " Press Continue when connections are complete "
840     PAUSE
850     CLEAR SCREEN
860     FOR I=0 TO 9
870     IF I<8 THEN J=I+108
880     IF I=8 THEN J=191
890     IF I=9 THEN J=192
900     OUTPUT @Mux;"CLOS (@"&VAL$(J)&")"
910     OUTPUT @Dmm;"TRIG SGL"
920     ENTER @Dmm;Value1(I,K)
930     OUTPUT @Mux;"OPEN (@"&VAL$(J)&")"
940     IF I<8 AND K=0 THEN Result1(I,K)=Value1(I,K)-R(23)
950     IF I<8 AND K=1 THEN Result1(I,K)=Value1(I,K)-R(24)
960     IF I<8 AND K=2 THEN Result1(I,K)=Value1(I,K)-R(25)
970     IF I=8 AND K=0 THEN Result1(I,K)=Value1(I,K)-(R(23)+R(29))
980     IF I=8 AND K=1 THEN Result1(I,K)=Value1(I,K)-(R(24)+R(30))

```

Continued on Next Page

```

990   IF I=8 AND K=2 THEN Result1(I,K)=Value1(I,K)-(R(25)+R(31))
1000  IF I=9 AND K=0 THEN Result1(I,K)=Value1(I,K)-(R(23)+R(26))
1010  IF I=9 AND K=1 THEN Result1(I,K)=Value1(I,K)-(R(24)+R(27))
1020  IF I=9 AND K=2 THEN Result1(I,K)=Value1(I,K)-(R(25)+R(28))
1030  IF Result1(I,K)<0. THEN Result1(I,K)=0.
1040  IF Result1(I,K)>2.0 THEN
1050    PRINT "Resistance for Channel";I;"Relay is >2.0 Ohms"
1060    PAUSE
1070  END IF
1080  NEXT I
1090  IF K<2 THEN
1100    PRINT "Measurements complete for Channels 08 - 15 and 91 -
92 ";Path$(K)
1110    DISP " Press Continue for Channels 08 - 15 and 91 - 92
";Path$(K+1);" measurements "
1120    PAUSE
1130  ELSE
1140    PRINT "Measurements complete for Channels 08 - 15 and 91 -
92 ";Path$(K)
1150    DISP " Press Continue to display measurement results "
1160    PAUSE
1170    CLEAR SCREEN
1180  END IF
1190  NEXT K
1200  !
1210                                     ! Display Relay Contact Resistances
1220  !
1230 Format:IMAGE 3(12X,D.2D,12X,D.2D,12X,D.2D,/)
1240 PRINT TABXY(1,1),"Channels 00-15 and 90-92 Relay Contact
Resistances "
1250 PRINT TABXY(1,3),"Channel   HI (OHMS)   LO (OHMS)   GU
(OHMS)"
1260 PRINT
1270 PRINT USING Format;Result0(*)
1280 FOR I=0 TO 8
1290  IF I<8 THEN PRINT TABXY(2,5+I),I
1300  IF I=8 THEN PRINT TABXY(3,13),"90"
1310 NEXT I
1320 PRINT USING Format;Result1(*)
1330 FOR J=8 TO 17
1340  IF J<16 THEN PRINT TABXY(2,J+1),J
1350  IF J=16 THEN PRINT TABXY(3,J+1),"91"
1360  IF J=17 THEN PRINT TABXY(3,J+1),"92"
1370 NEXT J
1380 END

```

Typical Results

Channel	HI (OHMS)	LO (OHMS)	GU (OHMS)
0	0.51	0.35	0.61
1	0.49	0.31	0.59
2	0.48	0.41	0.57
3	0.42	0.39	0.61
4	0.52	0.41	0.55
5	0.52	0.35	0.59
6	0.49	0.40	0.60
7	0.46	0.36	0.54
90	0.49	0.40	0.55
8	0.47	0.35	0.60
9	0.51	0.36	0.61
10	0.43	0.33	0.55
11	0.45	0.39	0.58
12	0.50	0.41	0.60
13	0.48	0.41	0.55
14	0.52	0.36	0.54
15	0.43	0.41	0.51
91	0.44	0.38	0.55
92	0.50	0.40	0.61

Test 2-2: DC Isolation Test

This test verifies that sufficient DC isolation exists at various points on the multiplexer. DC Isolation is checked from HI to Chassis, HI to LO, and HI to GU (GUARD). This test uses the test fixture (see Figure 2-1).

NOTE

The DMM used should be capable of measuring at least 1 G Ω . If the DMM indicates an overload, record the reading as >Rmax, where Rmax is the highest resistance that the DMM can measure. For example, if the DMM is an 3458A, a typical return for an overload is 1.E+38 and the entry in Table 2-2 should be >1.2 G Ω .

HI to Chassis Isolation

1. Make hardware connections as shown in Figure 2-9
2. Set DMM to 2-wire ohms, 1 G Ω range
3. Send CLOS (@nn00:nn15, nn90:nn93) to close all relays
4. Trigger the DMM with TRIG SGL
5. Record the DMM reading on Table 2-2 (HI to Chassis)

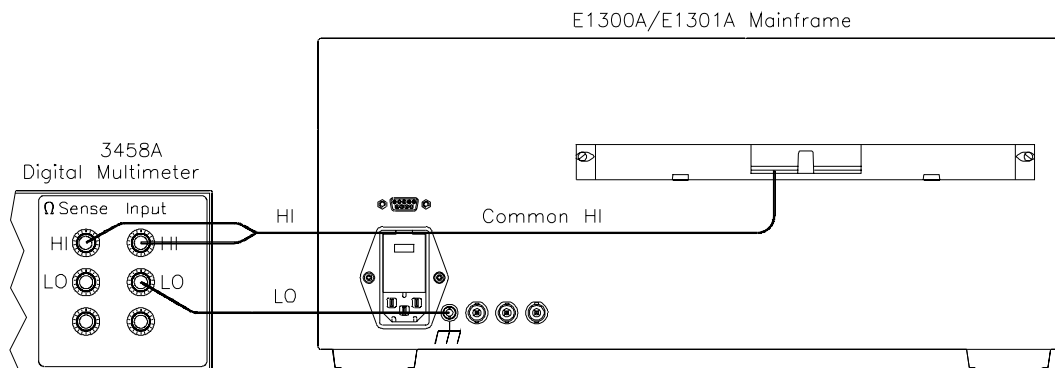

Figure 2-9. HI to Chassis Isolation Connections

HI to LO Isolation

1. Make hardware connections as shown in Figure 2-10
2. Trigger the DMM with TRIG SGL
3. Record the DMM reading on Table 2-2 (HI to LO)

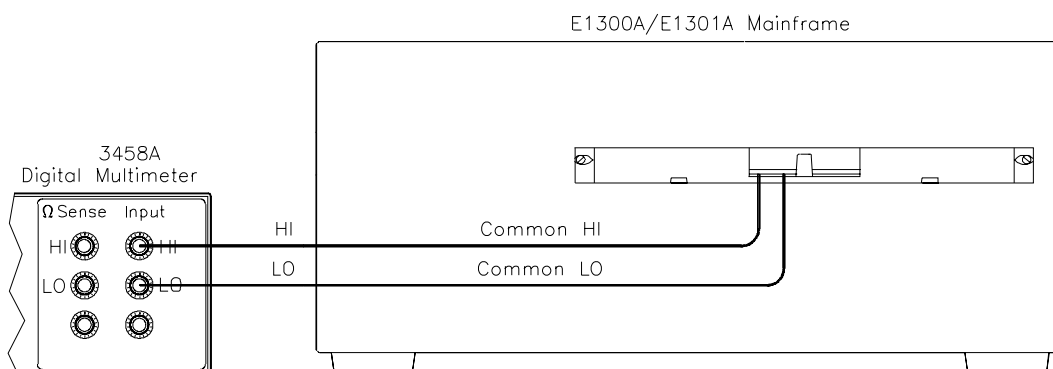

Figure 2-10. HI to LO Isolation Connections

HI to GU Isolation

1. Make hardware connections as shown in Figure 2-11
2. Trigger the DMM with TRIG SGL
3. Record the DMM reading on Table 2-2 (HI to GU)

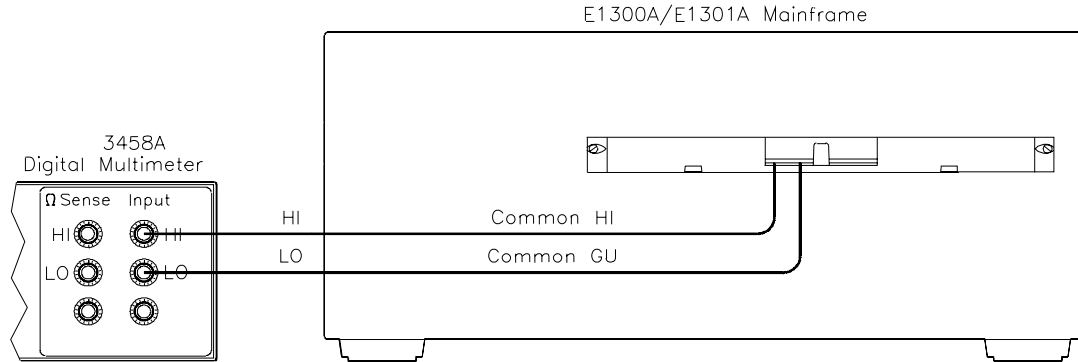

Figure 2-11. HI to GU Isolation Connections

Example: DC Isolation Test

This example performs DC Isolation Tests for HI to Chassis, HI to LO, and HI to GU (GUARD).

```
10 !RE-SAVE "DC_ISOL"
20 ASSIGN @Dmm TO 722
30 ASSIGN @Mux TO 70914
40 DISP CHR$(129)
50 DIM Conn$(5)[10]
60 DATA CHASSIS, LO, GU, CHASSIS, COMMON LO, COMMON GU
70 READ Conn$(*)
80 OUTPUT @Dmm;"OHM 1E9"
90 PRINT "Equipment Connections "
100 PRINT
110 PRINT " 1. Turn Mainframe power OFF"
120 PRINT " 2. Install E1345A Component Assembly into Mainframe "
130 PRINT " 3. Attach Test Fixture to Component Assembly"
140 PRINT " 4. Turn Mainframe power ON"
150 PRINT " 5. Press Continue when ready to begin testing "
```

Continued on Next Page

```

160 PAUSE
170 CLEAR SCREEN
180 !
190      ! Measure DC Isolation (HI to Chassis, HI to LO, HI to GU)
200 !
210 OUTPUT @Mux;"*RST"
220 FOR I=0 TO 2
230   PRINT TABXY(1,1),"DC Isolation HI to ";Conn$(I);" Measurements
   "
240   PRINT TABXY(1,3),"1. Connect DMM INPUT HI lead to COMMON
   HI"
250   PRINT TABXY(1,4),"2. Connect DMM INPUT LO to ";Conn$(I+3)
260   DISP " Press Continue when connections are complete "
270   PAUSE
280   CLEAR SCREEN
290   OUTPUT @Mux;"CLOS (@100:115,190:193)"
300   OUTPUT @Dmm;"TRIG SGL"
310   ENTER @Dmm;Value(I)
320 NEXT I
330 DISP " Press Continue to display measurement results "
340 PAUSE
350 CLEAR SCREEN
360 PRINT TABXY(1,1),"DC Isolation Tests "
370 PRINT TABXY(1,3),"HI to CHASSIS (Ohms)";Value(0)
380 PRINT TABXY(1,4),"HI to LO (Ohms)   ";Value(1)
390 PRINT TABXY(1,5),"HI to GUARD (Ohms) ";Value(2)
400 END

```

Typical Result A typical result for an overload on all three measurements is :

DC Isolation Tests	
HI to Chassis(Ohms)	1.E+38
HI to LO (Ohms)	1.E+38
HI to GUARD (Ohms)	1.E+38

Performance Test Record

Table 2-2, "Performance Test Record," is a form you may copy and use to record performance verification test results for the multiplexers. Table 2-2 shows multiplexer test limits, DMM measurement uncertainty, and test accuracy ratio (TAR) values.

Test Limits

Test limits are defined for relay closed channel resistance and DC isolation using the specifications in the individual module's User's Manual. The relay contact resistance and DC isolation specifications are single-ended, meaning that there is an upper limit OR a lower limit, but not both. In Table 2-2, the Minimum or Maximum column is blank for a single-sided test.

Measurement Uncertainty

For the performance verification tests in this manual, measurement uncertainties are calculated based on the 3458A Digital Multimeter. The measurement uncertainty shown in Table 2-2 is the accuracy of the 3458A using 90-day specifications. The calculations follow.

Closed Channel Resistance Test

Conditions:

- 4-wire ohms function, 10 Ω range
- 90-day specifications
- Worst-case reading = 2.0 Ω

$$\begin{aligned} \text{M.U.} &= (15 \text{ ppm of Reading} + 5 \text{ ppm of Range}) \\ &= (15 \times 10^{-6} \cdot 2.0 + 5 \times 10^{-6} \cdot 10) (\Omega) \\ &= \underline{8.0 \times 10^{-5} \Omega} \end{aligned}$$

DC Isolation Test

Conditions:

- 2-wire ohms function, 1 G Ω range
- 90-day specifications
- Worst-case reading = 1.2 G Ω (highest resistance that can be measured with the 3458A)

$$\begin{aligned} \text{M.U.} &= (0.5\% \text{ of Reading} + 10 \text{ ppm of Range}) \\ &= (0.005 \cdot 1.2 \times 10^9 + 10 \times 10^{-6} \cdot 1 \times 10^9) (\Omega) \\ &= \underline{6.0 \times 10^6 \Omega} \end{aligned}$$

Test Accuracy Ratio (TAR)

Test Accuracy Ratios (TAR) are not defined for single-sided measurements, so all closed-channel resistance and DC isolation measurements show NA (Not Applicable) in the TAR column.

Table 2-2. Performance Test Record (Page 1 of 3)

General Information

Test Facility:	
Name _____	Report No. _____
Address _____	Date _____
City/State _____	Customer _____
Phone _____	Tested by _____
Special Notes:	

Test Equipment Record

Model _____ Report No. _____ Date _____			
Test Equipment Used: Description	Model No.	Trace No.	Cal Due Date
1. _____	_____	_____	_____
2. _____	_____	_____	_____
3. _____	_____	_____	_____
4. _____	_____	_____	_____
5. _____	_____	_____	_____
6. _____	_____	_____	_____
7. _____	_____	_____	_____

Table 2-2. Performance Test Record (Page 2 of 3)

Test No/Description	Minimum* Value	Measured Value (V)	Maximum Value	Measurement Uncert	Test Acc Ratio (TAR)
2-1. Closed Channel Resistance (Values in Ohms)					
HI Path Resistance					
Channel 00			2.0	8.00E-5	NA
Channel 01			2.0	8.00E-5	NA
Channel 02			2.0	8.00E-5	NA
Channel 03			2.0	8.00E-5	NA
Channel 04			2.0	8.00E-5	NA
Channel 05			2.0	8.00E-5	NA
Channel 06			2.0	8.00E-5	NA
Channel 07			2.0	8.00E-5	NA
Channel 08			2.0	8.00E-5	NA
Channel 09			2.0	8.00E-5	NA
Channel 10			2.0	8.00E-5	NA
Channel 11			2.0	8.00E-5	NA
Channel 12			2.0	8.00E-5	NA
Channel 13			2.0	8.00E-5	NA
Channel 14			2.0	8.00E-5	NA
Channel 15			2.0	8.00E-5	NA
Channel 90			2.0	8.00E-5	NA
Channel 91			2.0	8.00E-5	NA
Channel 92			2.0	8.00E-5	NA
LO Path Resistance					
Channel 00			2.0	8.00E-5	NA
Channel 01			2.0	8.00E-5	NA
Channel 02			2.0	8.00E-5	NA
Channel 03			2.0	8.00E-5	NA
Channel 04			2.0	8.00E-5	NA
Channel 05			2.0	8.00E-5	NA
Channel 06			2.0	8.00E-5	NA
Channel 07			2.0	8.00E-5	NA
Channel 08			2.0	8.00E-5	NA
Channel 09			2.0	8.00E-5	NA
Channel 10			2.0	8.00E-5	NA
Channel 11			2.0	8.00E-5	NA
Channel 12			2.0	8.00E-5	NA
Channel 13			2.0	8.00E-5	NA
Channel 14			2.0	8.00E-5	NA
Channel 15			2.0	8.00E-5	NA
Channel 90			2.0	8.00E-5	NA
Channel 91			2.0	8.00E-5	NA
Channel 92			2.0	8.00E-5	NA

*Single-sided specification - Minimum value does not apply

Table 2-2. Performance Test Record (Page 3 of 3)

Test No/Description	Minimum* Value	Measured Value (V)	Maximum* Value	Meas Uncert	Test Acc Ratio (TAR)
2-1. Closed Channel Resistance (Values in Ohms) (cont'd)					
GU Path Resistance					
Channel 00		_____	2.0	8.00E-5	NA
Channel 01		_____	2.0	8.00E-5	NA
Channel 02		_____	2.0	8.00E-5	NA
Channel 03		_____	2.0	8.00E-5	NA
Channel 04		_____	2.0	8.00E-5	NA
Channel 05		_____	2.0	8.00E-5	NA
Channel 06		_____	2.0	8.00E-5	NA
Channel 07		_____	2.0	8.00E-5	NA
Channel 08		_____	2.0	8.00E-5	NA
Channel 09		_____	2.0	8.00E-5	NA
Channel 10		_____	2.0	8.00E-5	NA
Channel 11		_____	2.0	8.00E-5	NA
Channel 12		_____	2.0	8.00E-5	NA
Channel 13		_____	2.0	8.00E-5	NA
Channel 14		_____	2.0	8.00E-5	NA
Channel 15		_____	2.0	8.00E-5	NA
Channel 90		_____	2.0	8.00E-5	NA
Channel 91		_____	2.0	8.00E-5	NA
Channel 92		_____	2.0	8.00E-5	NA
2-2. DC Isolation (Values in Ohms)					
HI to CHASSIS	1E9	_____		6.0E6	NA
HI to LO	1E9	_____		6.0E6	NA
HI to GU	1E9	_____		6.0E6	NA

*Single-sided specification - Minimum value does not apply

**Single-sided specification - Maximum value does not apply

Introduction

This chapter contains information on ordering replaceable parts for the E1343A/44A/45A/47A/55A/56A Relay Multiplexers with specific serial number ranges. The tables provide the following information:

- Table 3-1 lists assembly and terminal module part numbers for the relay multiplexers.
- Table 3-2 lists replaceable parts for the following multiplexers:

E1345A with serial number 2934A07622 or higher
E1347A with serial number 2934A03663 or higher
E1355A with serial number 3035A00331 or higher
E1356A with serial number 3035A00457 or higher.

- Table 3-3 lists replaceable parts for the following high-voltage multiplexers:

E1343A with serial number 3131A00852 or higher
E1344A with serial number 3131A00512 or higher.

- Table 3-4 shows reference designators for parts in Tables 3-2 and 3-3.

To order a part listed in Tables 3-2 and 3-3, specify the Agilent part number and the quantity required. Send the order to your nearest Agilent Technologies Sales and Service Office.

NOTE If your multiplexer has a serial number lower than what is listed above, see Appendix B, "Backdating Information," for replaceable parts ordering information.

Replaceable Parts List

See the Parts Locator diagram (Figure 3-1) for locations of replaceable parts. See Table 3-1 for replacement part numbers for the Component Assemblies and Terminal Modules. A relay multiplexer consists of a Component Assembly and a Terminal Module.

A Terminal Module consists of a Terminal Card and a Terminal Case Assembly. For example, to order an E1345A Terminal Module, use E1345-80001. To order only the Terminal Card, use E1345-66510. To order only the Terminal Case Assembly, use E1300-84401.

Table 3-1. Relay Multiplexer Assembly/Terminal Module Part Numbers

Multiplexer	Component Assembly	Terminal Module	Terminal Card	Terminal Case Assy
E1343A 16-Channel High-Voltage Relay Mux	E1343-66201	E1343-80001	E1345-66510	E1300-84401
E1344A 16-Channel High-Voltage Relay Mux with TC	E1343-66201	E1344-80001	E1347-66510	E1300-84401
E1345A 16-Channel Mux	E1345-66201	E1345-80001	E1345-66510	E1300-84401
E1347A 16-Channel Mux w/TC	E1345-66201	E1347-80001	E1347-66510	E1300-84401
E1355A 120-Ohm Strain Relay Mux	E1345-66201	E1355-80001	E1355-66510	E1300-84401
E1356A 350-Ohm Strain Relay Mux	E1345-66201	E1356-80001	E1356-66510	E1300-84401

Table 3-2. E1345A/47A/55A/56A Replaceable Parts

(see applicable serial number ranges on first page of this chapter)

Reference Designator	Part Number	Qty	Part Description
ASSEMBLIES/TERMINAL MODULES/CABLES			
ASSEMBLIES/TERMINAL MODULES			
	E1345-66201	1	COMPONENT ASSEMBLY
	E1345-80001	1	E1345A TERMINAL MODULE
	E1347-80001	1	E1347A TERMINAL MODULE
	E1355-80001	1	E1355A TERMINAL MODULE
	E1356-80001	1	E1356A TERMINAL MODULE
CABLES			
	E1326-61601	1	RIBBON CABLE 6-PIN 3-IN E1326B TO RLY MUXS
	E1326-61604	1	RBN CBL 6-PIN 21-IN E1326A (INT) TO RLY MUXS
	E1326-61611	1	RBN CBL 6-PIN 20-IN E1326B (INT) TO RLY MUXS
	E1300-61605	1	RBN CABLE 6-PIN 2-IN RLY MUXS TO RLY MUXS
	E1400-61605	1	RBN CABLE 6-PIN 2.5-IN RLY MUXS TO RLY MUXS
COMPONENT ASSY (E1345-66201) (Common to E1345/47/55/56 Relay Muxs) See Figure 3-1			
BRK1-BRK2	0050-2183	2	CASTING-ZN P.C. BOARD HOLDER
LBL1	E1300-84308	1	LBL LOGO B SIZE
LBL2	E1300-84312	1	ID PLATE VXI (P & P)
F1-F2	2110-0936	2	FUSE-SUBMINIATURE 4A 125V SMT
J1	1252-1596	2	CONN-POST TYPE 2.54-PIN-SPCG 96-CONTACT
J2	1252-3712	1	CONN-POST TYPE .100-PIN-SPCG 12-CONTACT
K100-K115	0490-1707	20	RELAY-REED 3A 500MA 110VAC 5VDC-COIL 5VA
K90-K93			
MP1-MP2	1400-1546	2	BRACKET PC BOARD HOLDER; BLACK; EXTR
P1	1252-1596		CONN-POST TYPE 2.54-PIN-SPCG 96-CONTACT
PNL1	E1345-00202	1	PNL-RR RLY MUXR
SCR1-SCR2	0515-0444	2	SCREW-MACH PHD M2.5 X 0.45 8MM-LG HD
SCR3-SCR4	0515-1968	2	SCREW PHM 2.5 X 11 PAN - HD
SHD1	E1300-80601	1	SHIELD SAFETY - PLASTIC
SW1	3101-3142	1	SWITCH-DIP 8-1A SMTV 0.25A 24 VDC
SW2	3101-3148	1	SWITCH-DIP 4-1A SMT 0.05A 6 VDC

Table 3-2. E1345A/47A/55A/56A Replaceable Parts (cont'd)

Reference Designator	Part Number	Qty	Part Description
			TERMINAL MODULES
	E1345-80001	1	E1345A TERMINAL MODULE (See Figure 3-2)
A1	E1345-66510	1	TERMINAL CARD - 16 CH RLY MUX
CS	E1300-84401	1	CASE - TERMINAL MODULE ASSY
	E1347-80001	1	E1347A TERMINAL MODULE (See Figure 3-2)
A1	E1347-66510	1	TERMINAL CARD - 16 CH T/C MUX
CS	E1300-84401	1	CASE - TERMINAL MODULE ASSY
	E1355-80001		E1355A TERMINAL MODULE (See Figure 3-3)
A1	E1355-66510	1	TERMINAL CARD - 120 OHM STRAIN RLY MUX
CS	E1300-84401	1	CASE - TERMINAL MODULE ASSEMBLY
	E1356-80001	1	E1356A TERMINAL MODULE (See Figure 3-3)
A1	E1356-66510	1	TERMINAL CARD - 350 OHM STRAIN RLY MUX
CS	E1300-84401	1	CASE - TERMINAL MODULE ASSY

Table 3-3. E1343A/44A Replaceable Parts
(see applicable serial number ranges on first page of this chapter)

Reference Designator	Part Number	Qty	Part Description
ASSEMBLIES/TERMINAL MODULES/CABLES			
ASSEMBLIES/TERMINAL MODULES			
	E1343-66201	1	COMPONENT ASSEMBLY
	E1343-80001	1	E1343A TERMINAL MODULE
	E1344-80001	1	E1344A TERMINAL MODULE
CABLES			
	E1326-61601	1	RIBBON CABLE 6-PIN 3-IN E1326B TO RLY MUXS
	E1326-61604	1	RBN CBL 6-PIN 21-IN E1326A (INT) TO RLY MUXS
	E1326-61611	1	RBN CBL 6-PIN 20-IN E1326B (INT) TO RLY MUXS
	E1300-61605	1	RBN CABLE 6-PIN 2-IN RLY MUXS TO RLY MUXS
	E1400-61605	1	RBN CABLE 6-PIN 2.5-IN RLY MUXS TO RLY MUXS
COMPONENT ASSY (E1343-66201) (common to both E1343A/44A Relay Muxs) See Figure 3-1			
BRK1-BRK2	0050-2183	2	CASTING-ZN P.C. BOARD HOLDER
LBL1	E1300-84308	1	LBL LOGO B SIZE
LBL2	E1300-84312	1	ID PLATE VXI (P & P)
F1 - F2	2110-0936	2	FUSE-SUBMINIATURE 4A 125V SMT
J1	1252-1596	2	CONN-POST TYPE 2.54-PIN-SPCG 96-CONTACT
J2	1252-3712	1	CONN-POST TYPE .100-PIN-SPCG 12-CONTACT
K100-K115	0490-1584	20	RELAY-REED 3A 2A 350VAC 5VDC-COIL 5VA
K90-K93			
MP1-MP2	1400-1546	2	BRACKET PC BOARD HOLDER; BLACK; EXTR
P1	1252-1596		CONN-POST TYPE 2.54-PIN-SPCG 96-CONTACT
PNL1	E1343-00202	1	PNL-RR MUXR 16CH
SCR1-SCR2	0515-0444	2	SCREW-MACH PHD M2.5 X 0.45 8MM-LG - HD
SCR3-SCR4	0515-1968	2	SCREW PHM 2.5 X 11 PAN - HD
SHD1	E1300-80601	1	SHIELD SAFETY - PLASTIC
SW1	3101-3142	1	SWITCH-DIP 8-1A SMTV 0.25A 24 VDC
SW2	3101-3148	1	SWITCH-DIP 4-1A SMT 0.05A 6 VDC
TERMINAL MODULES			
	E1343-80001	1	E1343A TERMINAL MODULE (See Figure 3-2)
A1	E1345-66510	1	TERMINAL CARD - 16 CH RLY MUX
CS	E1300-84401	1	CASE - TERMINAL MODULE ASSY
	E1344-80001	1	E1344A TERMINAL MODULE (See Figure 3-2)
A1	E1347-66510	1	TERMINAL CARD - 16 CH T/C MUX
CS	E1300-84401	1	CASE - TERMINAL MODULE ASSY

Table 3-4. Reference Designators

Reference Designators				
A	assembly		PCB	printed circuit board
BRK	bracket		PNL	panel
C	capacitor		Q	transistor
CR	diode		R	resistor
CS	case		RP	resistor pack
F	fuse		RT	thermistor probe
J	electrical connector (jack)		SCR	screw
JM	jumper		SHD	shield
K	relay		SW	switch
LBL	label		TB	terminal module (block)
MP	mechanical part		U	integrated circuit
P	electrical connector (plug)			

Parts Locators

Figures 3-1 through 3-3 show locations of replaceable parts for the E1343A, E1344A, E1345A, E1347A, E1355A, and E1356A Relay Multiplexers with serial numbers that fall within a specific range. (See applicable serial number ranges on the first page of this chapter.) See Table 3-4 for Reference Designators. Schematic diagrams are provided at the back of this manual.

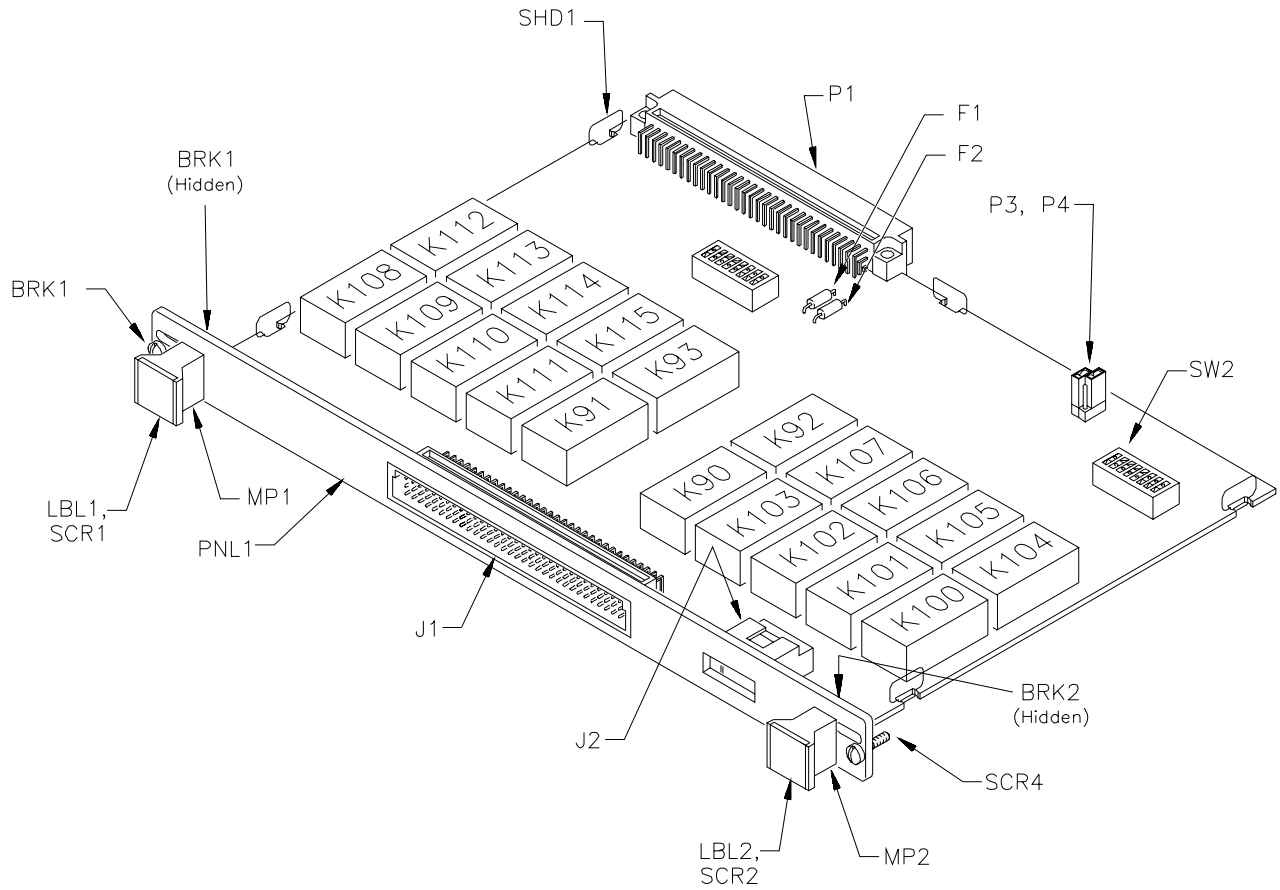

Figure 3-1. Component Assembly Parts

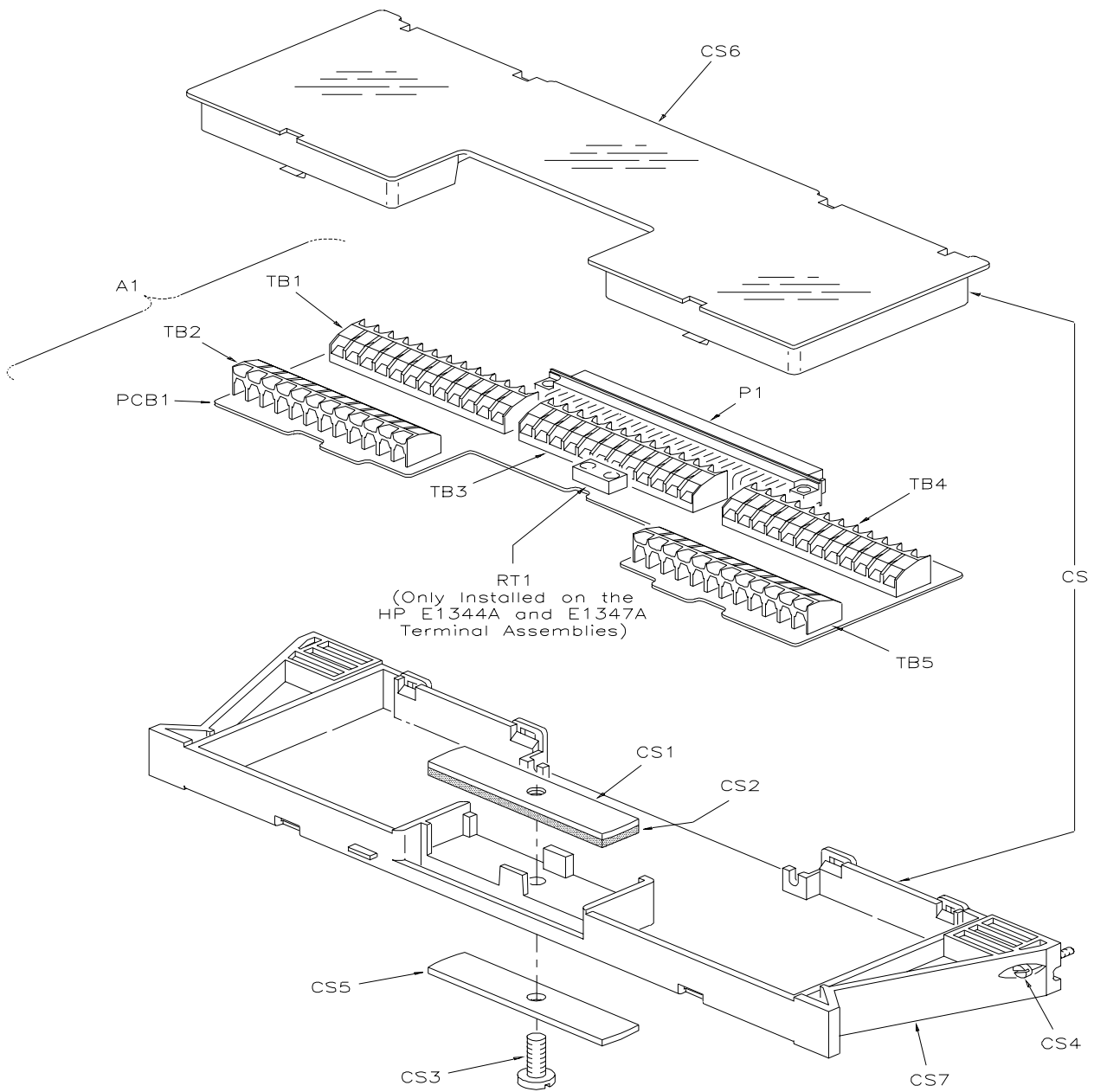

Figure 3-2. E1343A, E1344A, E1345A, E1347A Terminal Module Mechanical Parts

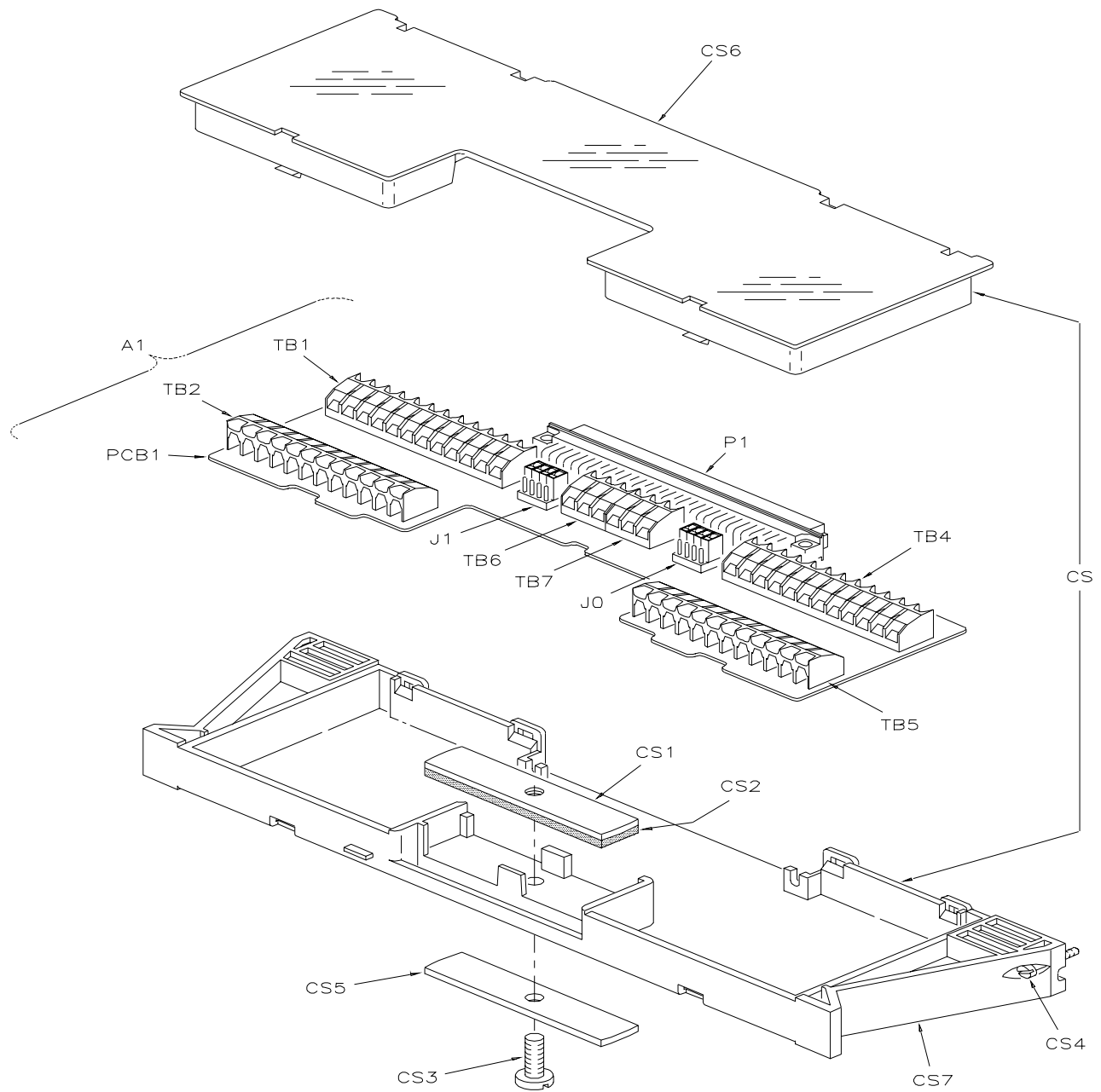

Figure 3-3. E1355A/E1356A Terminal Module Mechanical Parts

Introduction

This chapter contains generic service information for the multiplexers. Also included are troubleshooting, repair, and maintenance guidelines. Refer to the tables at the end of this chapter for information on the Parts Locator, Component Locator and Schematic Diagram drawings included with this manual.

WARNING Do not perform any of the service procedures shown unless you are a qualified, service-trained technician and have read the **WARNINGS** and **CAUTIONS** in Chapter 1.

Equipment Required

Equipment required for multiplexer troubleshooting and repair is listed in Table 1-1, "Recommended Test Equipment." Any equipment that satisfies the requirements given in the table may be substituted. To avoid damage to the screw head slots, use a T8 Torx driver to remove the front panel handles.

Service Aids

See Chapter 3, "Replaceable Parts," or Appendix B, "Backdating Information," for descriptions and locations of the replaceable parts, depending on the serial number of your multiplexer. Service notes, manual updates, and service literature for the multiplexers may be available through Agilent Technologies. For information, contact your nearest Agilent Technologies Sales and Service Office.

E1343A/44A Multiplexer Descriptions

The E1343A 16-Channel High Voltage Relay Multiplexer and the E1344A 16-Channel High Voltage Relay Multiplexer (with thermocouple compensation) modules consist of an E1343A component assembly (part number E1343-66201) and a terminal module. Each multiplexer provides switching (multiplexing) of up to 16 channels (channels 00 to 15). Each channel has HIGH (H), LOW (L), and GUARD (G) connections. See Figure 4-1 for a block diagram of these modules.

The component assembly is the same for the E1343A and E1344A. The only difference between the two component assemblies is their module ID jumper settings. The E1343A uses an E1343-80001 terminal assembly and the E1344A uses an E1344-80001 terminal assembly.

Component Assembly Description

The E1343A Component Assembly consists of 16 channel relays and four tree switch relays. The channel relay switches are separated into two banks, Bank 0 (channels 00 through 07) and Bank 1 (channels 08 to 15). Each bank has its own common H, L, and G terminals that connect to the channel switches.

The Bank 0 channel switches also connect to the AT Tree Switch Terminals (on the terminal module) via the AT Tree Switch (Channel 90) and three protection resistors (R26, R27, and R28). The Bank 1 channel switches connect to the BT Tree Switch terminals (on the terminal module) via the BT Tree Switch (Channel 91) and three protection resistors (R29, R30, and R31).

The AT2 Tree Switch (Channel 92) connects Bank 1 channels to the AT Tree Switch. For the E1347A only, the RT Tree Switch (Channel 93) connects the thermistor (on the terminal module) to the Bank 1 channel common. This allows measurement of the thermistor to compensate for temperature measurements made with thermocouples.

The AT Tree Switch connects to the H, L, and G connections on the Analog Bus Connector and the BT Tree Switch connects to the I+, I-, and IG connections on the Analog Bus Connector. The Analog Bus Connector provides direct channel connections between multiple multiplexer modules and connections between a multiplexer module and E1326/E1411 multimeters.

Each Bank 0 and Bank 1 Common line and AT and BT Tree Switch line has a 100Ω resistor in series to provide relay contact protection. The Analog Bus Connector also has six 100Ω resistor in series to provide current protection.

Terminal Module Description

The terminal module provides connections from user devices to the multiplexer. The terminal module also provides connections for multimeters, voltmeters, counters, and other measuring devices. For the E1344A only, a thermistor is mounted on the terminal module.

Terminal module connections include H, L, and G terminals for Channels 00 - 15, Bank 0 and Bank 1 Commons, and the AT and BT Tree Switches. In addition, each channel H line has a jumper on the terminal module that can be removed to add filter components, attenuators, or current shunts.

E1345A/47A Multiplexer Descriptions

The E1345A 16-Channel Relay Multiplexer and the E1347A 16-Channel Thermocouple Relay Multiplexer consist of an E1345A component assembly (E1345-66201) and a terminal module. Each multiplexer provides switching (multiplexing) of up to 16 channels (channels 00 to 15). Each channel has HIGH (H), LOW (L), and GUARD (G) connections. See Figure 4-1 for a block diagram of these modules.

The component assembly is the same for the E1345A and E1347A. The only difference between the two component assemblies is their jumper settings. The E1345A has an E1345-80001 terminal module and the E1347A has an E1347-80001 terminal module.

Component Assembly Description

The E1345A Component Assembly consists of 16 channel relays and four tree switch relays. The channel relay switches are separated into two banks, Bank 0 (channels 00 through 07) and Bank 1 (channels 08 to 15). Each bank has its own common H, L, and G terminals that connect to the channel switches.

The Bank 0 channel switches also connect to the AT Tree Switch Terminals (on the terminal module) via the AT Tree Switch (Channel 90) and three protection resistors (R26, R27, and R28). The Bank 1 channel switches connect to the BT Tree Switch terminals (on the terminal module) via the BT Tree Switch (Channel 91) and three protection resistors (R29, R30, and R31).

The AT2 Tree Switch (Channel 92) connects Bank 1 channels to the AT Tree Switch. For the E1347A only, the RT Tree Switch (Channel 93) connects the thermistor (on the terminal module) to the Bank 1 channel common. This allows measurement of the thermistor to compensate for temperature measurements made with thermocouples.

The AT Tree Switch connects to the H, L, and G connections on the Analog Bus Connector and the BT Tree Switch connects to the I+, I-, and IG connections on the Analog Bus Connector. The Analog Bus Connector provides direct channel connections between multiple multiplexer modules and connections between a multiplexer module and E1326/E1411 multimeters.

Each Bank 0 and Bank 1 Common line and AT and BT Tree Switch line has a 100Ω resistor in series to provide relay contact protection. The Analog Bus Connector also has six 100Ω resistor in series to provide current protection.

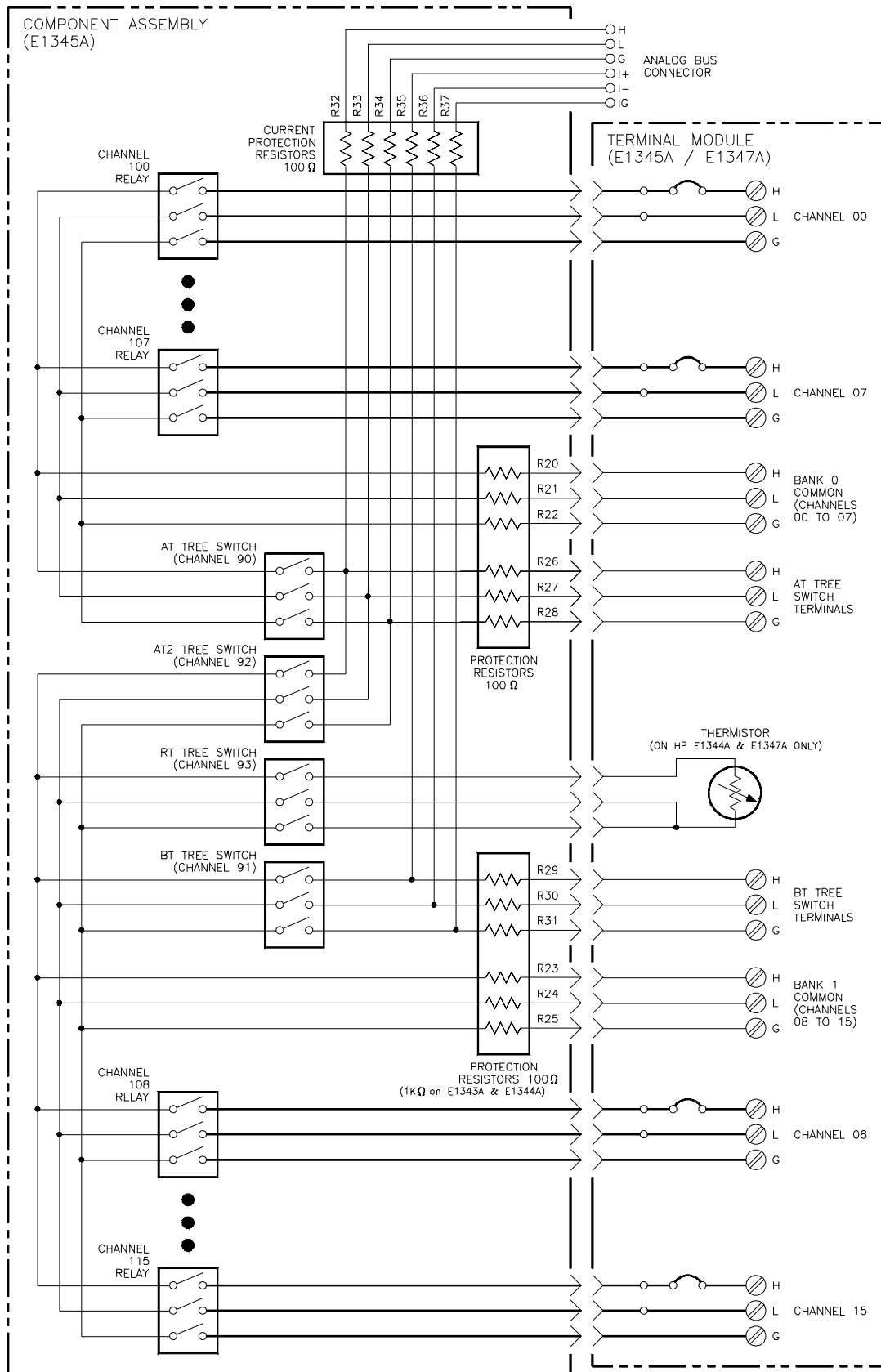

Figure 4-1. E1343A, E1344A, E1345A, E1347A Multiplexer Block Diagram

Terminal Module Description

The terminal module provides connections from user devices to the multiplexer. The terminal module also provides connections for multimeters, voltmeters, counters, and other measuring devices. For the E1347A only, a thermistor is mounted on the terminal module.

Terminal module connections include H, L, and G terminals for Channels 00 - 15, Bank 0 and Bank 1 Commons, and the AT and BT Tree Switches. In addition, each channel H line has a jumper on the terminal module that can be removed to add filter components, attenuators, or current shunts.

E1355A/56A Strain Gage Multiplexer Descriptions

The E1355A and E1356A multiplexers, together with an E1326B or E1411B multimeter, provide static and dynamic strain measurement capabilities for an Agilent 75000 Series B or 75000 Series C VXIbus system.

The E1355A and E1356A multiplexer are B-Size, 8-Channel, 120 Ω and 350 Ω relay strain gage multiplexers respectively. See Figure 4-2 for a block diagram of the E1355A 120 Ohm Relay Strain Gage Multiplexer. The block diagram shows a 1/4 bridge arrangement.

Each strain gage multiplexer provides switching (multiplexing) of up to eight channels. Each channel has HIGH (H), LOW (L), GUARD (G), +E, -E1, and -E2 connections to provide 1/4, 1/2, or full bridge arrangements. See the *E1355A - E1358A Strain Gage Multiplexers User's Manual* for a complete description of strain gage bridge arrangements.

The strain gage multiplexer module consists of a component assembly and a terminal module. The component assembly is the same for the E1355A and E1356A multiplexer modules. The only difference between the two component assemblies is their jumper settings. The E1355A has an E1355-80001 terminal module and the E1356A has an E1356-80001 terminal module.

Component Assembly Description

Relay switches and relay control logic are located on the E1345A Component Assembly. The component assembly can be configured to provide the strain gage excitation voltage, or this voltage can be supplied by the user. Refer to the *E1355A - E1358A Strain Gage Multiplexers User's Manual* for information on bridge excitation voltage configurations. Table 4-1 summarizes the functions of each relay on the component assembly.

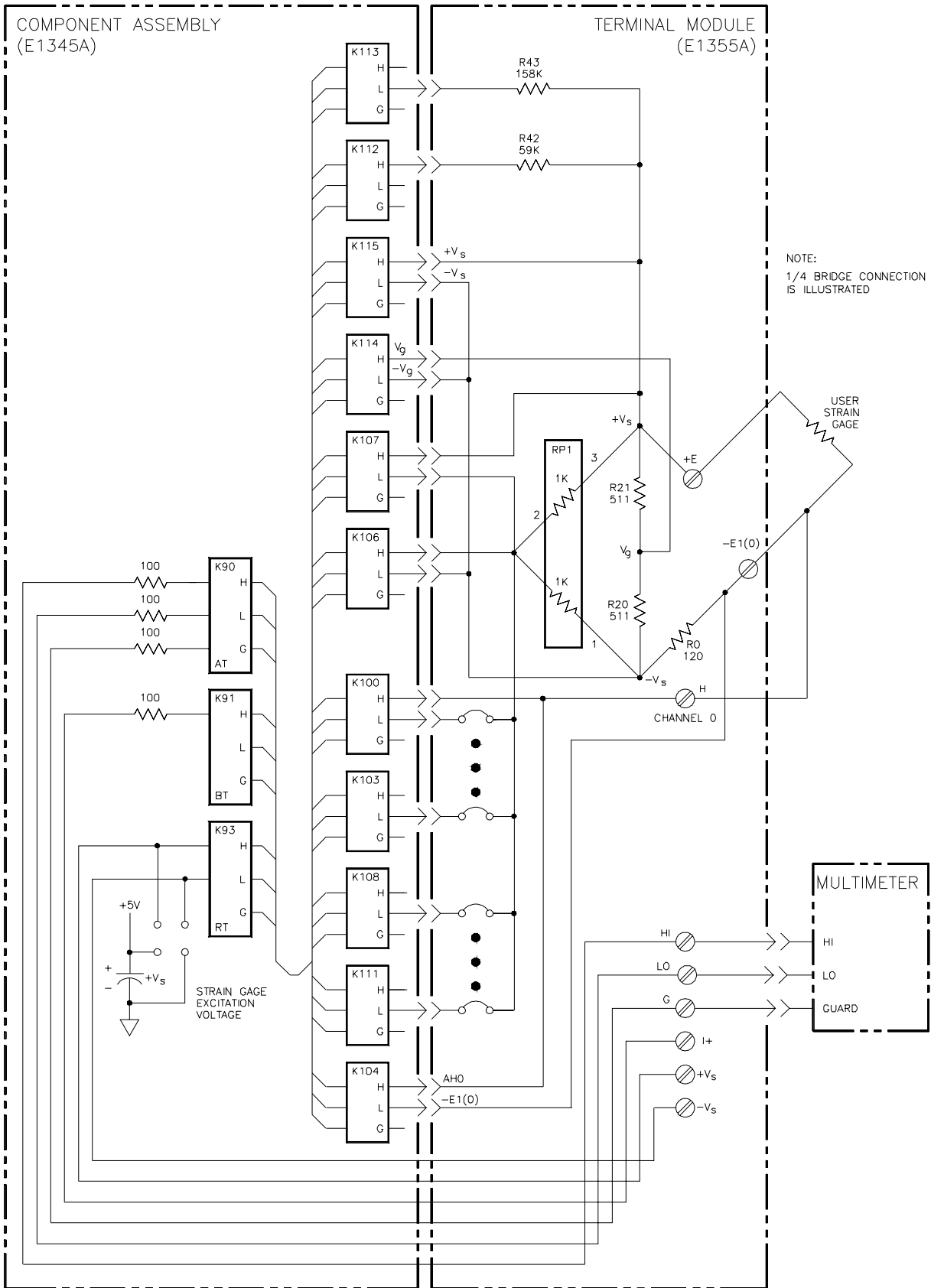

Figure 4-2. E1355A/56A Multiplexers Block Diagram

Table 4-1. E1355A/E1356A Relay Functions

Relay	Function	Notes
K100 K101 K102 K103	Measure strain (channel 00) Measure strain (channel 01) Measure strain (channel 02) Measure strain (channel 03)	All strain gage measurements are made via the K90 relay connected to a multimeter
K108 K109 K110 K111	Measure strain (channel 04) Measure strain (channel 05) Measure strain (channel 06) Measure strain (channel 07)	All strain gage measurements are made via the K90 relay when connected to a multimeter
K104 K105	Measure lead wire resistance (channel 08) Measure lead wire resistance (channel 09)	This measurement increases accuracy of strain gage measurements by canceling effects of lead wire resistance.
K106 K107	Measure voltage across 1K Ω bridge (channel 10) Measure voltage across 1K Ω bridge (channel 11)	These measurements check stability and condition of the resistor pack RP1.
K112 K113 K114 K115	Shunt verification test (channel 12) Shunt verification test (channel 13) Measure guard voltage (Vg) (channel 14) Measure bridge excitation voltage (+Vs) (chan 15)	Simulates known value of compression Simulates known value of tension Made with respect to the excitation voltage (-Vs)
K90 K91 K93	Strain gage measurements I+ source +Vs, -Vs excitation voltage	

Terminal Module Description

The terminal module contains the set of bridge resistors used in strain gage measurements. The two 1k Ω bridge resistors contained in the resistor pack (RP1) make up one half of the bridge arrangement. The other half of the bridge arrangement for channel 0 consists of a user-supplied 120 Ω strain gage and the 120 Ω resistor R0.

The junction (Vg) between the resistors R21 and R20 is known as a Wagner Ground. The purpose of the Wagner Ground is to reduce stray leakage currents when the Guard lead (G) is connected to the specimen being measured.

Troubleshooting Techniques

To troubleshoot a relay multiplexer problem, you must first identify the problem and then isolate the cause of the problem to a replaceable part. See Chapter 3, "Replaceable Parts," or Appendix B, "Backdating Information," for descriptions and locations of replaceable parts, depending on the serial number of your multiplexer.

NOTE If the problem cannot be isolated to a user-replaceable part, we suggest you return the multiplexer to Hewlett-Packard for repair, or order a replacement assembly. See Chapter 1, "General Information," for procedures to return multiplexers to Hewlett-Packard. See Chapter 3, "Replaceable Parts," for information on ordering replaceable parts.

Identifying the Problem

Table 4-2 lists some common problems for the relay multiplexers, along with symptoms and possible solutions. If the problem cannot be identified using these steps, perform component-level troubleshooting using the parts locator diagram in Chapter 3 (Figure 3-1) and the schematic diagrams located at the back of this manual.

Table 4-2. E1343A/44A/45A/47A/55A/56A Typical Problems

Problem Type	Symptom	Possible Solutions
Operator Errors	Non-zero error code in response to SYST:ERR?	For E1343A/44A/45A/47A, see Appendix C of the <i>E1343A/E1344A/E1345A/E1347A Relay Multiplexers User's Manual</i> For E1355A/56A, see Appendix E of the <i>E1355A - E1358A Strain Gage Multiplexers User's Manual</i>
Catastrophic Failure	Multiplexer not responding to commands.	See "Making Visual Checks" in this chapter
Performance Out of Specification	Multiplexer fails Closed Channel Resistance Test (Test 2-1) Multiplexer fails DC Isolation Test (Test 2-2)	See "Testing the Multiplexer" in this chapter Check user wiring and test fixture connections.

Making Visual Checks

Visual checks for the multiplexer assemblies include the following. See Table 4-3 for typical symptoms/actions.

- Check switches/jumpers
- Check for heat damage
- Check terminal module connections

NOTE

Refer to the appropriate user's manual for information on logical address and IRQ settings. If there are no apparent problems following the visual checks, run the Performance Verification Tests in Chapter 2 to see if a relay or other component is defective.

Table 4-3. E1343A/44A/45A/47A/55A/56A Visual Tests/Checks

Test/Check	Reference Designator	Check	Action/Notes
Heat Damage	----- ----- -----	Discolored PC boards Damaged insulation Evidence of arcing	If there is damage, do not operate the multiplexer until you have corrected the problem.
Switch/Jumper Settings	----- SW1 SW2	IRQ Level setting Logical address setting Card ID setting	Factory set at 1 Factory set at 112 Set to 45A, 47A, 55A, or 56A as appropriate for multiplexer
Component Assembly	F1, F2 J1 P1	Fuse continuity Dirty or bent connector pins Dirty or bent connector pins	Check fuses with ohmmeter Straighten/clean pins Straighten/clean pins
Terminal Module	P1 TB1 - TB5 J0, J1 (E1355A/56A)	Dirty or bent connector pins Loose screw connections Bridge connections	Straighten/clean pins Check/tighten connections Set for 1/4, 1/2, or full as required

Testing the Multiplexer

You can use the tests and checks in Chapter 2, "Verification Tests," and the information in Table 4-4 to isolate the problem to a relay, to a component, or both. For example, if Test 2-1: Closed Channel Resistance Test failed for channel 0, replace relay K100, etc. See Chapter 3, "Replaceable Parts," or Appendix B, "Backdating Information," for replaceable parts lists and locator diagrams, depending on the serial number of your multiplexer.

Table 4-4. Checks for Relay/Component Failures*

If Test 2-1 failed for this Channel:	Check/Replace these Relays/ICs:
Channel 00 Channel 01 Channel 02 Channel 03 Channel 04 Channel 05 Channel 06 Channel 07 Channel 08 Channel 09 Channel 10 Channel 11 Channel 12 Channel 13 Channel 14 Channel 15 Channels 00 - 07 Channels 08 - 15 Channel 90 Channel 91 Channel 92 Channels 90 - 92 Channels 00 - 15 and 90 - 92	K100 K101 K102 K103 K104 K105 K106 K107 K108 K109 K110 K111 K112 K113 K114 K115 U1, U21, U38 U2, U21, U30 K90 K91 K92 U3, U21, U25 CR2, Q1, U3, U6, U8, U12, U15, U20, U21, U22
If these items failed:	Replace:
Channel 93 Device Type ID CRESET failed	K93 U10 U9, U21

* See Test 2-1: Closed Channel Resistance Test for information.

Repair and Maintenance Guidelines

This section provides guidelines for handling the relay multiplexers including:

- ESD precautions
- Soldering printed circuit boards
- Post-repair safety checks

ESD Precautions

Electrostatic discharge (ESD) may damage static sensitive devices in the multiplexers. This damage can range from slight parameter degradation to catastrophic failure. When handling multiplexer assemblies, observe the following guidelines to avoid damaging multiplexer components:

- Always use a static-free work station with a pad of conductive rubber or similar material when handling multiplexer components.
- If a device requires soldering, be sure the assembly is placed on a pad of conductive material. Also, be sure that you, the pad, and the soldering iron tip are grounded to the assembly.

Soldering Printed Circuit Boards

Some of the components on the etched circuit boards of the multiplexer modules have plated through-holes that provide a solder path to both sides of the insulating material. Soldering can be done from either side of the board with equally good results. When soldering to any circuit board, keep in mind the following guidelines:

- Avoid unnecessary component unsoldering and soldering. Excessive replacement can result in damage to the circuit board, adjacent components, or both.
- Do not use a high power soldering iron on etched circuit boards, as excessive heat may lift a conductor or damage the board.
- Use a suction device or wooden toothpick to remove solder from component mounting holes. When using a suction device, be sure that the equipment is properly grounded.

Post-Repair Safety Checks

After making repairs to the multiplexer, inspect the multiplexer for any signs of abnormal internally generated heat, such as discolored printed circuit boards or components, damaged insulation, or evidence of arcing. Determine and correct the cause of the condition. Then perform the functional tests as described in Chapter 2, "Verification Tests," to verify that the multiplexer is functional.

Component Locators and Schematic Diagrams

The following tables list Component Locator Diagrams and Schematic Diagrams provided with this manual. Refer to Table 4-5 or Table 4-6, depending on the serial number of your E1343/44/45/47/55/56A multiplexer. Table 4-7 lists the terminal module diagrams. The terminal module diagram table applies to all E1343A/44A/45A/47A/56A/57A multiplexers, regardless of their serial number.

Table 4-5. Relay Multiplexers Component Locator and Schematic Diagram Drawings for relay multiplexers with the following serial number ranges:

E1343A with serial number 3131A00852 and higher
 E1344A with serial number 3131A00512 and higher
 E1345A with serial number 2934A07622 and higher
 E1347A with serial number 2934A03663 and higher
 E1355A with serial number 3035A00331 and higher
 E1356A with serial number 3035A00457 and higher

	Part Number	Drawing Number	Drawing Title
Parts Locator	E1345-66511		See Figure 3-1 (Chapter 3)
Schematic Diagrams	E1345-66511	S-E1345-66511 (pg 1)	E1343A/E1344A/E1345A/E1347A/E1355A/E1356A - VXI Interface #1
	E1345-66511	S-E1345-66511 (pg 2)	E1343A/E1344A/E1345A/E1347A/E1355A/E1356A - VXI Interface #2
	E1345-66511	S-E1345-66511 (pg 3)	E1343A/E1344A/E1345A/E1347A/E1355A/E1356A - Relay Drivers
	E1345-66511	S-E1345-66511 (pg 4)	E1343A/E1344A/E1345A/E1347A/E1355A/E1356A - Relays
	E1345-66511	S-E1345-66511 (pg 5)	E1343A/E1344A/E1345A/E1347A/E1355A/E1356A - Part Location

Table 4-6. Relay Multiplexers Component Locator and Schematic Diagram Drawings for relay multiplexers with the following serial number ranges:

E1343A with serial number 2934A00001 through 3131A00851
 E1344A with serial number 2934A00001 through 3131A00511
 E1345A with serial number 2934A00001 through 2934A07621
 E1347A with serial number 2934A00001 through 2934A03662
 E1355A with serial number 2934A00001 through 3035A00330
 E1356A with serial number 2934A00001 through 3035A00456

	Part Number	Drawing Number	Drawing Title
Component Locator	E1345-66501	L-E1345-66501	Relay Multiplexers Component Assembly (all modules)
Schematic Diagrams	E1345-66501	S-E1345-66501 (pg 1)	Relay Multiplexers Component Assembly - VXI Interface #1
	E1345-66501	S-E1345-66501 (pg 2)	Relay Multiplexers Component Assembly - VXI Interface #2
	E1345-66501	S-E1345-66501 (pg 3)	Relay Multiplexers Component Assembly - Relay Drivers
	E1343-66501	S-E1343-66501 (pg 4)	Relay Multiplexers Component Assembly - Relays (E1343A/44A)
	E1345-66501	S-E1345-66501 (pg 5)	Relay Multiplexers Component Assembly - Relays (E1345A/47A/55A/56A)

**Table 4-7. Terminal Module Component Locator and Schematic Diagram Drawings
(for all E1343A/44A/45A/47A/55A/56A Relay Multiplexers, regardless of serial number)**

	Part Number	Drawing Number	Drawing Title
Component Locators	E1345-66510 E1347-66510 E1355-66510 E1356-66510	L-E1345-66510 L-E1347-66510 L-E1355-66510 L-E1356-66510	E1343A/E1345A 16-Ch. Relay Multiplexer Terminal Card E1344A/E1347A 16-Ch. Thermocouple Relay Multiplexer Terminal Card E1355A 8-Ch. 120 Ohm Strain Relay Multiplexer Terminal Card E1356A 8-Ch. 350 Ohm Strain Relay Multiplexer Terminal Card
Schematic Diagrams	E1345-66510 E1347-66510 E1355-66510 E1356-66510	S-E1345-66510 S-E1347-66510 S-E1355-66510 S-E1356-66510	E1343A/E1345A 16-Ch. Relay Multiplexer Terminal Card E1344A/E1347A 16-Ch. Thermocouple Relay Multiplexer Terminal Card E1355A 8-Ch. 120 Ohm Strain Relay Multiplexer Terminal Card E1356A 8-Ch. 350 Ohm Strain Relay Multiplexer Terminal Card

Appendix A

Verification Tests - C Programs

Functional Verification Test

These programs are designed to do the Functional Verification Tests found in Chapter 2, "Verification Tests."

Example: Self-Test The Functional Verification Test for the multiplexer modules consists of sending the *IDN? command and checking the response. This test can be used to verify that the multiplexer is connected properly and is responding to a basic command.

```
#include <stdio.h>
#include <sicl.h>

#define ADDR "hpib7,9,14"                /* Address of device */

void main (void)
{
    INST id;                             /* Define id as an instrument */
    char a[256] = {0};                   /* Result variable */
    int i;

    ionerror (I_ERROR_EXIT);
    id = iopen (ADDR);                   /* Open instrument session */

    iprintf(id, "**IDN?\n");               /* Send *IDN? command */
    iscanf (id, "%t", a);                 /* Get response */

    printf("\n %s", a);                   /* Print result */
    getchar();                             /* Pause */

    iclose (id);                          /* Close instrument session */
}
```

Performance Verification Tests

These programs are designed to do the Performance Verification Tests found in Chapter 2, "Verification Tests."

Example: Closed Channel Resistance Test

The following program performs a Closed Channel Resistance Test on Channels 00 - 15 and 90 - 92 HI, LO, and GU. If the contact resistance for a channel is $> 2.0 \Omega$, the program displays the message `Resistance for Channel chan Relay is > 2.0 Ohms.`

```
/* Closed-channel Resistance Test      E1346A */

#include <stdio.h>
#include <sicl.h>

#define ADDR "hpib7,9,14"              /* Address of device */
#define DMM "hpib7,22"                /* Address of multimeter */

void main (void)
{
    INST id, dm;                       /* Define id and dm as instruments */
    int channel, i, j;
    double ohm, R[6], result[48], value[48], result1[3][3], value1[3][3];
    char cr[256] = {0};

    #if defined(__BORLANDC__) && !defined(__WIN32__)
        _InitEasyWin();
    #endif

    ionerror(I_ERROR_EXIT);

    /* Open instrument session */
    dm = iopen (DMM);
    itimeout (dm, 10000);

    iprintf (dm, "PRESET NORM\n");
    iprintf (dm, "END ALWAYS\n");
    iprintf (dm, "TRIG HOLD\n");
    iprintf (dm, "FUNC OHMF\n");

    /* .....Measure Protection Resistors..... */

    printf ("\n\nMeasure Protection Resistors R38 - R43");
    printf ("\n\n 1. Turn mainframe power OFF.");
    printf ("\n\n 2. Remove E1346A component assembly from mainframe.");
    printf ("\n\nPress ENTER when ready to measure protection resistors.");

    getchar ();
    printf ("\n\n");

    for (i = 0; i <= 5; i++)
    {
        printf ("\nConnect DMM leads (4-wire) to resistor R%u", i+38);
        printf ("\nPress ENTER when ready to measure resistance");
        getchar ();
    }
}
```

```

    iprintf (dm, "TRIG SGL\n");
    iscanf (dm, "%lf", &R[i]);
    iscanf (dm, "%t", cr);
    printf ("\nResistance of R%u = %lf", i+38, R[i]);
}

printf ("\n\nInstall Component Assembly and Test Fixture");
printf ("\n\n 1. Turn Mainframe AND 3458a DMM power OFF.");
printf ("\n\n 2. Connect HP-IB Cable between mainframe and DMM.");
printf ("\n\n 3. Install E1364A Component Assembly into Mainframe.");
printf ("\n\n 4. Attach Test Fixture to Component Assembly.");
printf ("\n\n 5. Turn Mainframe and DMM power ON");
printf ("\n\n 6. Press ENTER when ready to begin testing.");
getchar ();

/*.....Measure Channels 00-47 and 90-92 (HI, Lo, and G).....*/

id = iopen(ADDR);
iprintf (id, "**RST\n");
iprintf (dm, "PRESET NORM;TRIG HOLD\n");
iprintf (dm, "END ALWAYS\n");
iprintf (dm, "FUNC OHMF\n");

j = 100;
printf ("\n\nChannel 00-47 and 90-92 HI measurements");
printf ("\n\n 1. Connect DMM Sense and Input HI leads to COMMON HI.");
printf ("\n\n 2. Connect DMM Sense and Input LO leads to VOLTAGE SENSE HI.");
printf ("\n\n 3. Press ENTER when connections are complete.");
getchar ();

for (i = 0; i <= 47; i++)
{
    iprintf (id, "CLOS (@%u)\n", j+i);
    iprintf (dm, "TRIG SGL\n");
    iscanf (dm, "%lf", &value[i]);
    iscanf (dm, "%t", cr);
    iprintf (id, "OPEN (@%u)\n", j+i);
    result[i] = value[i] - R[5];

    if (result[i] < 0) result[i] = 0;
    if (result[i] > 2.0) printf ("\n*** Resistance for Channel %u HI path is 2.0 Ohms
*** %lf", i, result[i]);
}

printf ("\n\nMeasurements complete for Channels 00-47 and 90-92 HI");
printf ("\n\nPress ENTER for Channels 90-92 LO measurements");
getchar ();

/*.....Measure Channels 90-92 LO.....*/

iprintf (id, "**RST\n");

printf ("\n\nChannels 90-92 LO measurements");

printf ("\n\n 1. Connect DMM Sense and Input HI leads to COMMON LO.");
printf ("\n\n 2. Connect DMM Sense and Input LO leads to VOLTAGE SENSE
LO.");
printf ("\n\n 3. Press ENTER when connections are complete.");
getchar ();

```

```

j = 100;
for (i = 0; i <= 2; i++)
{
    iprintf (id, "CLOS (@%u)\n", j);
    iprintf (dm, "TRIG SGL\n");
    iscanf (dm, "%lf", &value1[i][1]);
    iscanf (dm, "%t", cr);
    iprintf (id, "OPEN (@%u)\n", i*8);
    result1[i][1] = value1[i][1] - R[42];

    if (result1[i][1] < 0) result1[i][1] = 0;
    if (result1[i][1] > 2.0) printf ("\n*** Resistance for Channel %u LO Relay is 2.0
Ohms", i+90);

    j = j + 8;
}

printf ("\n\nMeasurements complete for Channels 90-92 LO.");
printf ("\nPress ENTER for Channel 90-92 G measurements.");
getchar ();

/*.....Measure Channels 90-92 G.....*/

printf ("\n\nChannels 90-92 G measurements");
printf ("\n\n 1. Connect DMM Sense and Input HI leads to COMMON G.");
printf ("\n\n 2. Connect DMM Sense and Input LO leads to VOLTAGE SENSE G.");
printf ("\n\n 3. Press ENTER when connections are complete.");
getchar ();

j = 100;
for (i = 0; i <= 2; i++)
{
    iprintf (id, "CLOS (@%u)\n", j);
    iprintf (dm, "TRIG SGL\n");
    iscanf (dm, "%lf", &value1[i][2]);
    iscanf (dm, "%t", cr);
    iprintf (id, "OPEN (@%u)\n", i*8);
    result1[i][2] = value1[i][2] - R[42];

    if (result1[i][2] < 0) result1[i][2] = 0;
    if (result1[i][2] > 2.0) printf ("\n*** Resistance for Channel %u G Relay is 2.0
Ohms", i+90);

    j = j + 8;
}

printf ("\n\nMeasurements complete for Channels 90-92 G.");
printf ("\nPress ENTER for Channel 93 HI, LO, and G measurements.");
getchar ();

/*.....Measure Channel 93 HI, LO, and G.....*/

j = 193;
printf ("\n\nChannel 93 HI, LO, and G measurements");
printf ("\n\n 1. Connect DMM Sense and Input HI leads to VOLTAGE SENSE
HI.");

printf ("\n\n 2. Connect DMM Sense and Input LO leads to CURRENT SOURCE
HI.");
printf ("\n\n 3. Press ENTER when connections are complete.");

```

```

getchar ();

iprintf (id, "CLOS (@%u)\n", j);
iprintf (dm, "TRIG SGL\n");
iscanf (dm, "%lf", &value1[0][3]);
iscanf (dm, "%t", cr);
result1[0][3] = value1[0][3] - R[38] - R[43];
iprintf (id, "open (@%u)\n", j);

if (result1[0][3] < 0) result1[0][3] = 0;
if (result1[0][3] > 2.0) printf ("\n*** Resistance for Channel 93 HI Relay is 2.0
Ohms");

printf ("\n\n 1. Connect DMM Sense and Input HI leads to VOLTAGE SENSE
LO.");
printf ("\n 2. Connect DMM Sense and Input LO leads to CURRENT SOURCE
LO.");
printf ("\n 3. Press ENTER when connections are complete.");
getchar ();

iprintf (id, "CLOS (@%u)\n", j);
iprintf (dm, "TRIG SGL\n");
iscanf (dm, "%lf", &value1[1][3]);
iscanf (dm, "%t", cr);
result1[1][3] = value1[1][3] - R[39] - R[42];
iprintf (id, "open (@%u)\n", j);

if (result1[1][3] < 0) result1[1][3] = 0;
if (result1[1][3] > 2.0) printf ("\n*** Resistance for Channel 93 LO Relay is 2.0
Ohms");

printf ("\n\n 1. Connect DMM Sense and Input HI leads to VOLTAGE SENSE
G.");
printf ("\n 2. Connect DMM Sense and Input LO leads to CURRENT SOURCE
G.");
printf ("\n 3. Press ENTER when connections are complete.");
getchar ();

iprintf (id, "CLOS (@%u)\n", j);
iprintf (dm, "TRIG SGL\n");
iscanf (dm, "%lf", &value1[2][3]);
iscanf (dm, "%t", cr);
result1[2][3] = value1[2][3] - R[40] - R[41];
iprintf (id, "open (@%u)\n", j);

if (result1[2][3] < 0) result1[2][3] = 0;
if (result1[2][3] > 2.0) printf ("\n*** Resistance for Channel 93 G Relay is 2.0
Ohms");

printf ("\n\nMeasurements complete for Channel 93 HI, LO, and G.");
printf ("\nPress ENTER to display measurement results.");
getchar ();

/*.....Display Measurement Results.....*/

printf ("\n\n\nChannels 00-47 & 90-92 HI Contact Resistance\n");
for (i = 0; i <= 23; i++)
{
printf ("\n CH %u & %u %6.4lf Ohms CH %u & %u %6.4lf
Ohms", i, 90+(i/8), result[i], i+24, 90+(i/8), result[i+24]);
}

```

```

printf ("\n\nChannels 90-92 LO and G Contact Resistance\n");
printf ("\n CH 90 LO %6.4lf Ohms CH 91 LO %6.4lf Ohms CH 92 LO %6.4lf
Ohms", result1[0][1],result1[1][1],result1[2][1]);
printf ("\n CH 90 G %6.4lf Ohms CH 91 G %6.4lf Ohms CH 92 G %6.4lf
Ohms", result1[0][2],result1[1][2],result1[2][2]);

printf ("\n\nChannel 93 HI, LO, and G Contact Resistance\n");

printf ("\n CH 93 HI %6.4lf Ohms\n CH 93 LO %6.4lf Ohms\n CH 93 G
%6.4lf Ohms\n",result1[0][3],result1[1][3],result1[2][3]);

fclose (id);
fclose (dm); /* Close instrument session */
}

```

Example: DC Isolation Test This example performs DC Isolation Tests for HI to Chassis, HI to LO, and HI to GU (Guard).

```

/* DC Isolation Test      E1346A */

#include <stdio.h>
#include <sicl.h>

#define ADDR "hpib7,9,14" /* Address of device */
#define DMM "hpib7,22" /* Address of multimeter */

void main (void)
{
INST id, dm; /* Define id and dm as instruments */
*/
char reading[256]= {0}; /* Result variable */
char cr[256]= {0};

#ifdef __BORLANDC__ && !defined(__WIN32__)
_initEasyWin();
#endif

ionerror(I_ERROR_EXIT);

id = iopen (ADDR); /* Open instrument session */
dm = iopen (DMM);

iprintf (dm, "PRESET NORM;TRIG HOLD\n");
iprintf (dm, "FUNC OHM;RANGE 1E9\n");
iprintf (dm, "END ALWAYS\n");

iprintf (id, "*RST\n");
iprintf (id, "CLOS (@193,100,108,116)\n");

/* .....HI to CHASSIS..... */

printf ("\n\nConnect DMM HI and LO to E1346A COMMON HI and CHASSIS");
getchar ();

```

```

    fprintf (dm, "TRIG SGL\n");
    fscanf (dm, "%t", reading);
    printf ("\nDC Isolation -- HI to CHASSIS ");
    printf (" R = %s Ohms", reading);

/*.....HI to LO.....*/

    printf ("\n\nConnect DMM HI and LO to E1346A COMMON HI and COMMON
LO");
    getchar ();
    fprintf (dm, "TRIG SGL\n");
    fscanf (dm, "%t", reading);

    printf ("\nDC Isolation -- HI to LO ");
    printf (" R = %s Ohms", reading);

/*.....HI to GUARD.....*/

    printf ("\n\nConnect DMM HI and LO to E1346A COMMON HI and COMMON G");
    getchar ();
    fprintf (dm, "TRIG SGL\n");
    fscanf (dm, "%t", reading);
    printf ("\nDC Isolation -- HI to GUARD ");
    printf (" R = %s Ohms", reading);
/*.....*/

    fprintf (id, "OPEN (@193,100,108,116)\n");

    fclose (id);
    fclose (dm);
}
/* Close instrument session */

```

Notes

Appendix B

Backdating Information

Introduction

This chapter contains information for ordering replaceable parts for the E1343A/44A/45A/47A/55A/56A Relay Multiplexers with specific serial number ranges not covered in Chapter 3. The tables provide the following:

- Table B-1 lists assembly and terminal module part numbers for the relay multiplexers.
- Table B-2 lists replaceable parts for the following relay multiplexers:

E1345A w/serial number 2934A00001 through 2934A07621
E1347A w/serial number 2934A00001 through 2934A03662
E1355A w/serial number 2934A00001 through 3035A00330
E1356A w/serial number 2934A00001 through 3035A00456

- Table B-3 lists replaceable parts for the following high-voltage multiplexers:

E1343A w/serial number 2934A00001 through 3131A00851
E1344A w/serial number 2934A00001 through 3035A00511

- Table B-4 shows reference designators for parts in Tables B-2 and B-3.

To order a part listed in Table B-2 or Table B-3, specify the Agilent part number and the quantity required. Send the order to your nearest Agilent Technologies Sales and Service Office

NOTE If your multiplexer has a higher serial number, see Chapter 3, "Replaceable Parts," for replaceable parts ordering information.

Replaceable Parts List

See the Parts Locator diagram (Fig. B-1) or the Component Locator (in the back of this manual) for locations of replaceable parts. See Table B-1 for replacement part numbers for the Component Assemblies and Terminal Modules. A relay multiplexer consists of a Component Assembly and a Terminal Module.

A Terminal Module consists of a Terminal Card and a Terminal Case Assembly. For example, to order an E1345A Terminal Module, use

E1345-80001. To order only the Terminal Card, use E1345-66510. To order only the Terminal Case Assembly, use E1300-84401.

Table B-1. Relay Multiplexer Assembly/Terminal Module Part Numbers

Multiplexer	Component Assembly	Terminal Module	Terminal Card	Terminal Case Assy
E1343A 16-Channel High Voltage Relay Mux	E1343-66201	E1343-80001	E1345-66510	E1300-84401
E1344A 16-Channel High Voltage Relay Mux with TC	E1343-66201	E1344-80001	E1347-66510	E1300-84401
E1345A 16-Channel Mux	E1345-66201	E1345-80001	E1345-66510	E1300-84401
E1347A 16-Channel Mux w/TC	E1345-66201	E1347-80001	E1347-66510	E1300-84401
E1355A 120 Ohm Strain Rly Mux	E1345-66201	E1355-80001	E1355-66510	E1300-84401
E1356A 350 Ohm Strain Rly Mux	E1345-66201	E1356-80001	E1356-66510	E1300-84401

Table B-2. E1345A/47A/55A/56A Replaceable Parts

(See applicable Serial Number ranges listed on the first page of this chapter)

Reference Designator	Part Number	Qty	Part Description
			ASSEMBLIES/TERMINAL MODULES/CABLES
			ASSEMBLIES/TERMINAL MODULES
	E1345-66201	1	COMPONENT ASSEMBLY
	E1345-80001	1	E1345A TERMINAL MODULE
	E1347-80001	1	E1347A TERMINAL MODULE
	E1355-80001	1	E1355A TERMINAL MODULE
	E1356-80001	1	E1356A TERMINAL MODULE
			CABLES
	E1326-61601	1	RIBBON CABLE 6-PIN 3-IN E1326B TO RLY MUXS
	E1326-61604	1	RBN CBL 6-PIN 21-IN E1326A (INT) TO RLY MUXS
	E1326-61611	1	RBN CBL 6-PIN 20-IN E1326B (INT) TO RLY MUXS
	E1300-61605	1	RBN CABLE 6-PIN 2-IN RLY MUXS TO RLY MUXS
	E1400-61605	1	RBN CABLE 6-PIN 2.5-IN RLY MUXS TO RLY MUXS
			COMPONENT ASSEMBLY (HP E1345-66201) (Common to HP E1345/47/55/56 Relay Muxs) See Figure B-1 and Component Locator in back of manual.
BRK1-BRK2	0050-2183	2	CASTING-ZN P.C. BOARD HOLDER
LBL1	E1300-84308	1	LBL LOGO B SIZE
LBL2	E1300-84312	1	ID PLATE VXI (P & P)
F1	2110-0712	1	FUSE-SUBMINIATURE 4A 125V NTD AX
F2	2110-0665	1	FUSE-SUBMINIATURE 1A 125V NTD AX UL CSA

Reference Designator	Part Number	Qty	Part Description
			COMPONENT ASSY (CONT'D...HP E1345-66201)
J1	1252-1596	2	CONN-POST TYPE 2.54-PIN-SPCG 96-CONTACT
J2	1252-3712	1	CONN-POST TYPE .100-PIN-SPCG 12-CONTACT
J3	1251-6001	1	CONN-POST TYPE .100-PIN-SPCG 6-CONTACT
K0-K15	0490-1707	20	RELAY-REED 3A 500MA 110VAC 5VDC-COIL 5VA
K90-K93			
MP1-MP2	1400-1546	2	BRACKET PC BOARD HOLDER; BLACK; EXTR
P1	1252-1596		CONN-POST TYPE 2.54-PIN-SPCG 96-CONTACT
P3-P4	1258-0141	2	JUMPER-REMOVABLE FOR .025 IN SQ PINS
PNL1	E1345-00202	1	PNL-RR RLY MUXR
SCR1-SCR2	0515-0444	2	SCREW-MACH PHD M2.5 X 0.45 8MM-LG - HD
SCR3-SCR4	0515-1968	2	SCREW PHM 2.5 X 11 PAN - HD
SHD1	E1300-80601	1	SHIELD SAFETY - PLASTIC
SW1	3101-3066	1	SWITCH-DIP ROCKER 8-1A 0.15A 30 VDC
A1			PRINTED CIRCUIT ASSY, 16 CHAN MULTI
A1C1	0180-1746	2	CAPACITOR-FXD 15uF +-0% 20 V TA
A1C2-C3	0160-4822	3	CAPACITOR-FXD 1000pF +-5% 100 V CER C0G
A1C5	0160-4801	4	CAPACITOR-FXD 100pF +-5% 100 V CER C0G
A1C6	0160-4822		CAPACITOR-FXD 1000pF +- 5% 100 V CER C0G
A1C7-C9	0160-4801		CAPACITOR-FXD 100pF +-5% 100 V CER C0G
A1C11	0160-3334	1	CAPACITOR-FXD 0.01uF +-10% 50 V CER X7R
A1C17	0160-4835	9	CAPACITOR-FXD 0.1uF +-10% 50V CER X7R
A1C38-C42	0160-4835		CAPACITOR-FXD 0.1uF +-10% 50V CER X7R
A1C44	0180-1746		CAPACITOR-FXD 15uF +-10% 20 V TA
A1C45-C46	0160-4835		CAPACITOR-FXD 0.1uF +-10% 50V CER X7R
A1C48	0160-4835		CAPACITOR-FXD 0.1uF +-10% 50V CER X7R
A1CR1	1902-0554	1	DIODE-ZENER 10V 5% PD=1W IR=10UA
A1CR2	1901-1065	1	DIODE-POWER RECTIFIER 1N4936 400V 1A 200NS
A1JM15-JM16	7175-0057	2	RESISTOR 0 MFS
A1Q1	1855-0518	1	TRANSISTOR MOSFET N-CHAN E-MODE SI
A1R2	0757-0453	1	RESISTOR 30.1K +-1% .125W TF TC=0+-100
A1R3	0698-3615	1	RESISTOR 47 +-5% 2W MO TC=0+-200
A1R5	0698-8737	1	RESISTOR 100K +-5% .25W CC TC=-400/+800
A1R6-R7	0757-0465	2	RESISTOR 100K +-1% .125W TF TC=0+-100
A1R9	0757-0417	1	RESISTOR 562 +-1% .125W TF TC=0+-100
A1R10	0757-0442	1	RESISTOR 10K +-1% .125W TF TC=0+-100
A1R20-R37	0698-8768	18	RESISTOR 100 +-5% .25W CC TC=-400/+500
A1RP1-RP3	1810-0265	3	NETWORK-RESISTOR 16-DIP 680.0 OHM X 8
A1RP25-RP26	1810-0279	3	NETWORK-RES 10-SIP 4.7K OHM X 9
A1RP32	1810-0279		NETWORK-RES 10-SIP 4.7K OHM X 9

Reference Designator	Part Number	Qty	Part Description
COMPONENT ASSY (CONT'D...HP E1345-66201)			
A1U1-U3	1858-0069	3	TRANSISTOR ARRAY 18-PIN PLASTIC DIP
A1U5	1820-4057	1	IC BUFFER TTL/F NAND QUAD 2-INP
A1U6	1820-6731	1	IC GATE-ARRAY CMOS
A1U7-U8	1820-3079	2	IC DCDR CMOS/74HC BIN 3-TO-8-LINE
A1U9	1820-3081	1	IC FF CMOS/74HC D-TYPE POS-EDGE-TRIG
A1U10-U11	1820-3975	2	IC-DRIVER CMOS/74HC LINE OCTAL
A1U12	1820-4590	1	IC MV CMOS/74HC MONOSTBL RETRIG DUAL
A1U15	1820-4147	1	IC LCH CMOS/74HCT TRANSPARENT OCTL
A1U16	1820-3714	2	IC TRANSCEIVER TTL/ALS BUS OCTL
A1U17-U18	1820-3631	2	IC COMPARATOR CMOS/74HCT MAGTD 8-BIT
A1U19	1820-3664	1	IC GATE CMOS/HCT NAND QUAD 2-INP
A1U20	1820-4242	1	IC SCHMITT-TRIG CMOS/74HCT INV HEX
A1U21-U22	1820-4643	2	IC GATE CMOS/74HCT NOR QUAD 2-INP
A1U25	1820-4086	3	IC FF CMOS/74HCT D-TYPE POS-EDGE-TRIG
A1U30	1820-4086		IC FF CMOS/74HCT D-TYPE POS-EDGE-TRIG
A1U35	1820-3714		IC TRANSCEIVER TTL/ALS BUS OCTL
A1U38	1820-4086		IC FF CMOS/74HCT D-TYPE POS-EDGE-TRIG
	E1345-80001	1	E1345A TERMINAL MODULE (See Figure B-2)
A1	E1345-66510	1	TERM CARD - 16 CH RLY MUX
CS	E1300-84401	1	CASE - TERM MODULE ASSY
	E1347-80001	1	E1347A TERMINAL MODULE (See Figure B-2)
A1	E1347-66510	1	TERM CARD - 16 CH T/C MUX
CS	E1300-84401	1	CASE - TERM MODULE ASSY
	E1355-80001	1	E1355A TERMINAL MODULE (See Figure B-3)
A1	E1355-66510	1	TERM CARD - 120 OHM STRAIN RLY MUX
CS	E1300-84401	1	CASE - TERM MODULE ASSY
	E1356-80001	1	E1356A TERMINAL MODULE (See Figure B-3)
A1	E1356-66510	1	TERM CARD - 350 OHM STRAIN RLY MUX
CS	E1300-84401	1	CASE - TERM MODULE ASSY

Table B-3. E1343A, E1344A Replaceable Parts

(See applicable Serial Number ranges listed on the first page of this chapter))

Reference Designator	Part Number	Qty.	Part Description
ASSEMBLIES/TERMINAL MODULES/CABLES			
ASSEMBLIES/TERMINAL MODULES			
	E1343-66201	1	COMPONENT ASSEMBLY
	E1343-80001	1	E1343A TERMINAL MODULE
	E1344-80001	1	E1344A TERMINAL MODULE
CABLES			
	E1326-61601	1	RIBBON CABLE 6-PIN 3-IN E1326B TO RLY MUXS
	E1326-61604	1	RBN CBL 6-PIN 21-IN E1326A (INT) TO RLY MUXS
	E1326-61611	1	RBN CBL 6-PIN 20-IN E1326B (INT) TO RLY MUXS
	E1300-61605	1	RBN CABLE 6-PIN 2-IN RLY MUXS TO RLY MUXS
	E1400-61605	1	RBN CABLE 6-PIN 2.5-IN RLY MUXS TO RLY MUXS
COMPONENT ASSY (E1343-66201)			
(Common to both E1343A/44A Relay Muxs)			
See Figure B-1 and Component Locator in back of manual.			
BRK1-BRK2	0050-2183	2	CASTING-ZN P.C. BOARD HOLDER
LBL1	E1300-84308	1	LBL LOGO B SIZE
LBL2	E1300-84312	1	ID PLATE VXI (P & P)
F1	2110-0712	1	FUSE-SUBMINIATURE 4A 125V NTD AX
F2	2110-0665	1	FUSE-SUBMINIATURE 1A 125V NTD AX UL CSA
J1	1252-1596	2	CONN-POST TYPE 2.54-PIN-SPCG 96-CONTACT
J2	1252-3712	1	CONN-POST TYPE .100-PIN-SPCG 12-CONTACT
J3	1251-6001	1	CONN-POST TYPE .100-PIN-SPCG 6-CONTACT
K0-K15	0490-1584	20	RELAY-REED 3A 2A 350VAC 5VDC-COIL 5VA
K90-K93			
MP1-MP2	1400-1546	2	BRACKET PC BOARD HOLDER; BLACK; EXTR
P1	1252-1596	2	CONN-POST TYPE 2.54-PIN-SPCG 96-CONTACT
P3-P4	1258-0141	2	JUMPER-REMOVABLE FOR .025 IN SQ PINS
PNL1	E1343-00202	1	PNL-RR MUXR 16CH
SCR1-SCR2	0515-0444	2	SCREW-MACH PHD M2.5 X 0.45 8MM-LG - HD
SCR3-SCR4	0515-1968	2	SCREW PHM 2.5 X 11 PAN - DH
SHD1	E1300-80601	1	SHIELD SAFETY - PLASTIC
SW1	3101-3066	1	SWITCH-DIP ROCKER 8-1A 0.15A 30 VDC

Reference Designator	Part Number	Qty.	Part Description
COMPONENT ASSY (CONT'D...E1343-66201)			
A1			
PRINTED CIRCUIT ASSY, 16 CHAN MULTI			
A1C1	0180-1746	2	CAPACITOR-FXD 15uF +-10% 20 V TA
A1C2-C3	0160-4822	3	CAPACITOR-FXD 1000pF +-5% 100 V CER C0G
A1C5	0160-4801	4	CAPACITOR-FXD 100pF +-5% 100 V CER C0G
A1C6	0160-4822		CAPACITOR-FXD 1000pF +-5% 100 V CER C0G
A1C7-C9	0160-4801		CAPACITOR-FXD 100pF +-5% 100 V CER C0G
A1C11	0160-3334	1	CAPACITOR-FXD 0.01uF +-10% 50 V CER X7R
A1C17	0160-4835	9	CAPACITOR-FXD 0.1uF +-10% 50V CER X7R
A1C38-C42	0160-4835		CAPACITOR-FXD 0.1uF +-10% 50V CER X7R
A1C44	0180-1746		CAPACITOR-FXD 15uF +-10% 20 V TA
A1C45-C46	0160-4835		CAPACITOR-FXD 0.1uF +-10% 50V CER X7R
A1C48	0160-4835		CAPACITOR-FXD 0.1uF +-10% 50V CER X7R
A1CR1	1902-0554	1	DIODE-ZENER 10V 5% PD=1W IR=10UA
A1CR2	1901-1065	1	DIODE-POWER RECTIFIER 1N4936 400V 1A 200NS
A1JM15-JM16	7175-0057	2	RESISTOR 0 MFS
A1Q1	1855-0518	1	TRANSISTOR MOSFET N-CHAN E-MODE SI
A1R2	0757-0453	1	RESISTOR 30.1K +-1% .125W TF TC=0+-100
A1R3	0698-3615	1	RESISTOR 47 +-5% 2W MO TC=0+-200
A1R5	0698-8737	1	RESISTOR 100K +-5% .25W CC TC=-400/+800
A1R6-R7	0757-0465	2	RESISTOR 100K +-1% .125W TF TC=0+-100
A1R9	0757-0417	1	RESISTOR 562 +-1% .125W TF TC=0+-100
A1R10	0757-0449	1	RESISTOR 20K +-1% .125W TF TC=0+-100
A1R20-R21	0698-8768	12	RESISTOR 100 +-5% .25W CC TC=-400/+500
A1R22	0698-8777	6	RESISTOR 1k +-5% .25W CC TC=-400/+900
A1R23-R24	0698-8768		RESISTOR 100 +-5% .25W CC TC=-400/+500
A1R25	0698-8777		RESISTOR 1k +-5% .25W CC TC=-400/+900
A1R26-R27	0698-8768		RESISTOR 100 +-5% .25W CC TC=-400/+500
A1R28	0698-8777		RESISTOR 1k +-5% .25W CC TC=-400/+900
A1R29-R30	0698-8768		RESISTOR 100 +-5% .25W CC TC=-400/+500
A1R31	0698-8777		RESISTOR 1k +-5% .25W CC TC=-400/+900
A1R32-R33	0698-8768		RESISTOR 100 +-5% .25W CC TC=-400/+500
A1R34	0698-8777		RESISTOR 1k +-5% .25W CC TC=-400/+900
A1R35-R36	0698-8768		RESISTOR 100 +-5% .25W CC TC=-400/+500
A1R37	0698-8777		RESISTOR 1k +-5% .25W CC TC=-400/+900
A1RP1-RP3	1810-0265	3	NETWORK-RESISTOR 16-DIP 680.0 OHM X 8
A1RP25-RP26	1810-0279	3	NETWORK-RES 10-SIP 4.7K OHM X 9
A1RP32	1810-0279		NETWORK-RES 10-SIP 4.7K OHM X 9
A1U1-U3	1858-0069	3	TRANSISTOR ARRAY 18-PIN PLASTIC DIP
A1U5	1820-4057	1	IC BUFFER TTL/F NAND QUAD 2-INP

Reference Designator	Part Number	Qty.	Part Description
COMPONENT ASSY (CONT'D...E1343-66201)			
A1U6	1820-6731	1	IC GATE-ARRAY CMOS
A1U7-U8	1820-3079	2	IC DCDR CMOS/74HC BIN 3-TO-8-LINE
A1U9	1820-3081	1	IC FF CMOS/74HC D-TYPE POS-EDGE-TRIG
A1U10-U11	1820-3975	2	IC-DRIVER CMOS/74HC LINE OCTAL
A1U12	1820-4590	1	IC MV CMOS/74HC MONOSTBL RETRIG DUAL
A1U15	1820-4147	1	IC LCH CMOS/74HCT TRANSPARENT OCTL
A1U16	1820-3714	2	IC TRANSCEIVER TTL/ALS BUS OCTL
A1U17-U18	1820-3631	2	IC COMPARATOR CMOS/74HCT MAGTD 8-BIT
A1U19	1820-3664	1	IC GATE CMOS/HCT NAND QUAD 2-INP
A1U20	1820-4242	1	IC SCHMITT-TRIG CMOS/74HCT INV HEX
A1U21-U22	1820-4643	2	IC GATE CMOS/74HCT NOR QUAD 2-INP
A1U25	1820-4086	3	IC FF CMOS/74HCT D-TYPE POS-EDGE-TRIG
A1U30	1820-4086		IC FF CMOS/74HCT D-TYPE POS-EDGE-TRIG
A1U35	1820-3714		IC TRANSCEIVER TTL/ALS BUS OCTL
A1U38	1820-4086		IC FF CMOS/74HCT D-TYPE POS-EDGE-TRIG
TERMINAL MODULES			
	E1343-80001	1	E1343A TERMINAL MODULE (See Figure B-2)
A1	E1345-66510	1	TERM CARD - 16 CH RLY MUX
CS	E1300-84401	1	CASE - TERM MODULE ASSY
	E1344-80001	1	E1344A TERMINAL MODULE (See Figure B-2)
A1	E1347-66510	1	TERM CARD - 16 CH T/C MUX
CS	E1300-84401	1	CASE - TERM MODULE ASSY

Table B-4. Reference Designators

Reference Designators				
A	assembly		PCB	printed circuit board
BRK	bracket		PNL	panel
C	capacitor		Q	transistor
CR	diode		R	resistor
CS	case		RP	resistor pack
F	fuse		RT	thermistor probe
J	electrical connector (jack)		SCR	screw
JM	jumper		SHD	shield
K	relay		SW	switch
LBL	label		TB	terminal block (module)
MP	mechanical part		U	integrated circuit
P	electrical connector (plug)			

Parts Locators

Figures B-1 through B-3 show locations of replaceable parts for the E1343A, E1344A, E1345A, E1347A, E1355A, and E1356A Relay Multiplexers with serial numbers that fall within a specific range. (See applicable serial number ranges on the first page of this chapter.) See Table B-4 for Reference Designators. A more detailed component locator and schematic diagrams are provided at the back of this manual.

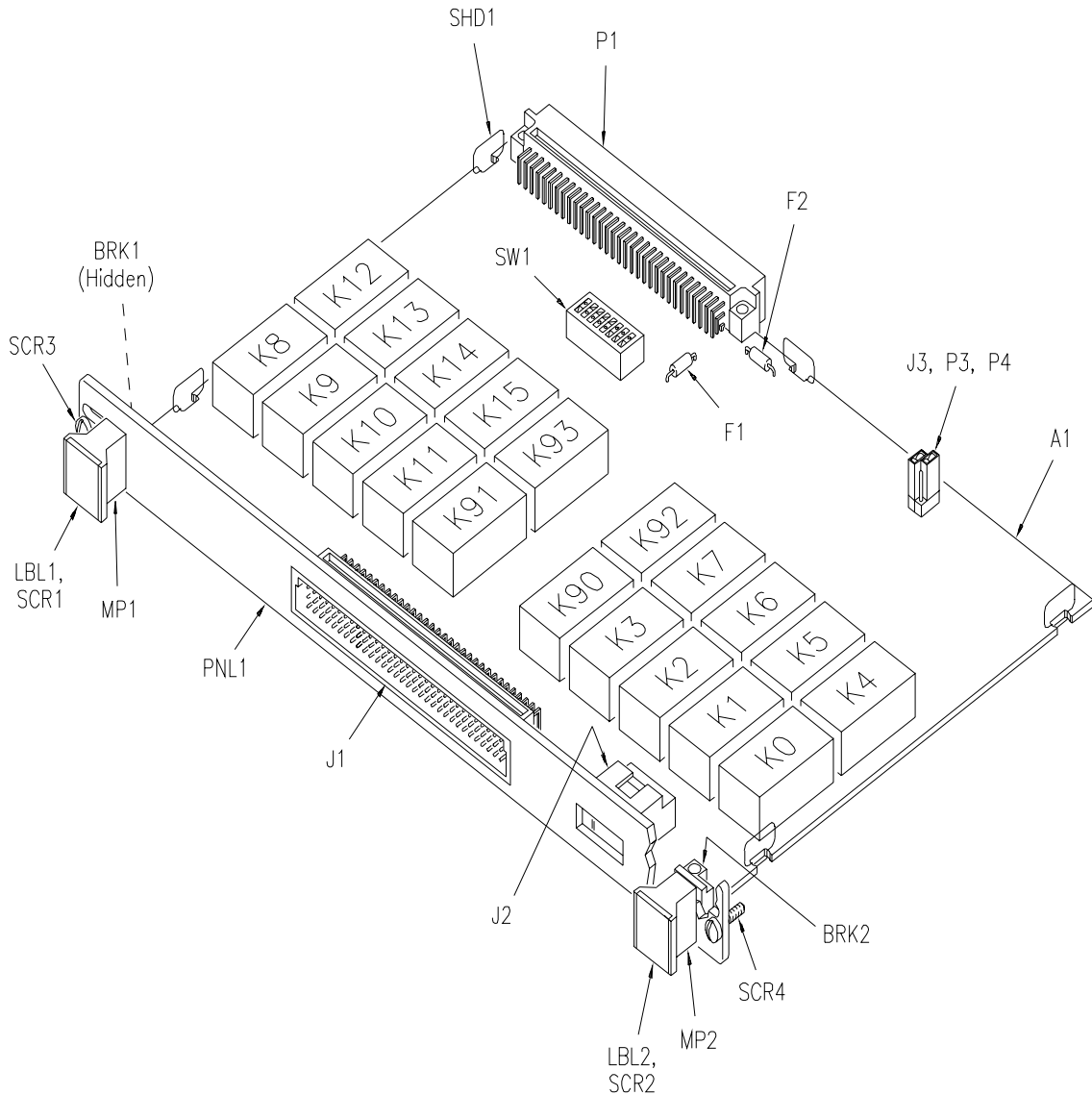

Figure B-1. Component Assembly Parts

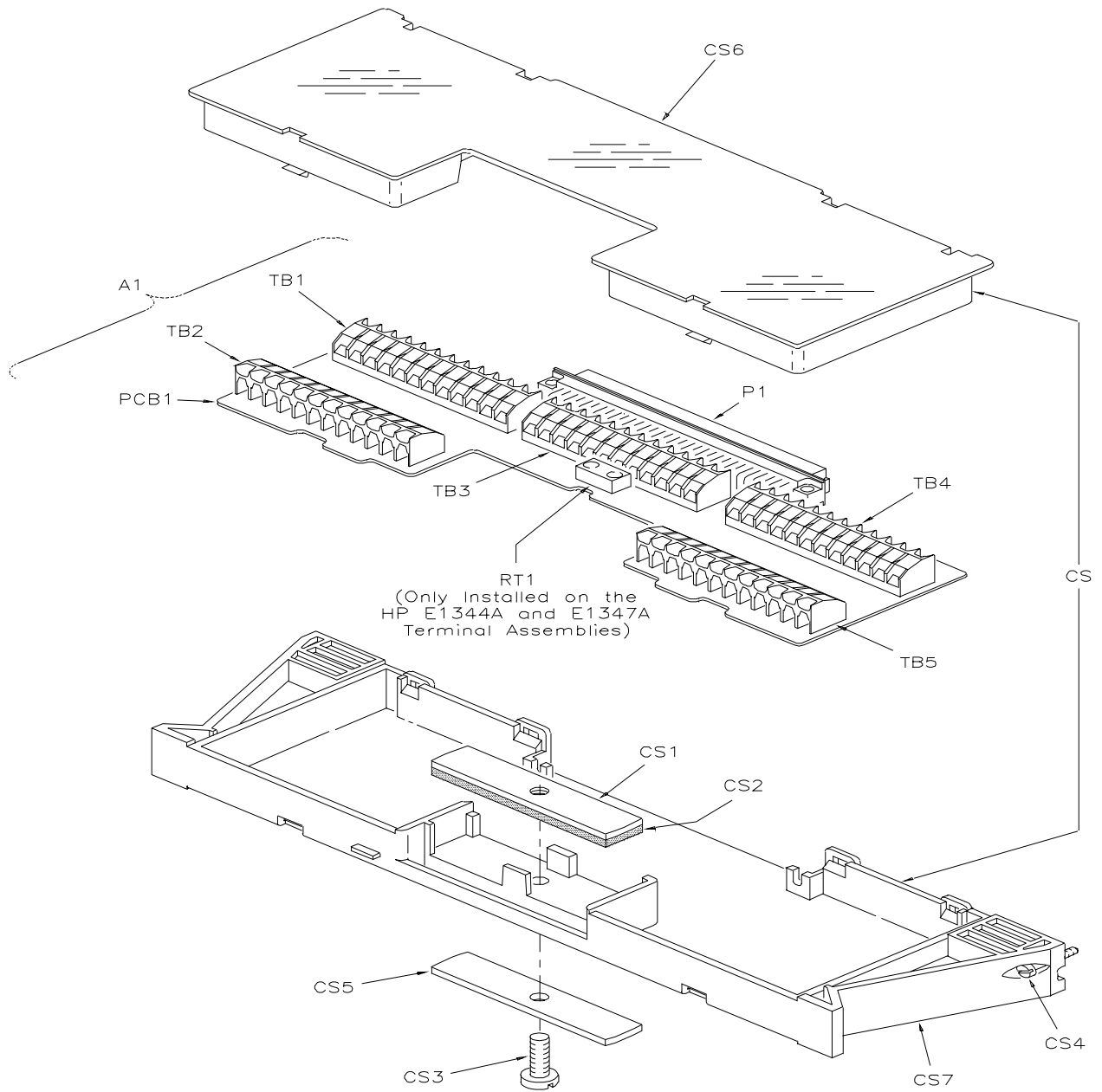

Figure B-2. E1343A/44A/45A/47A Terminal Module Mechanical Parts

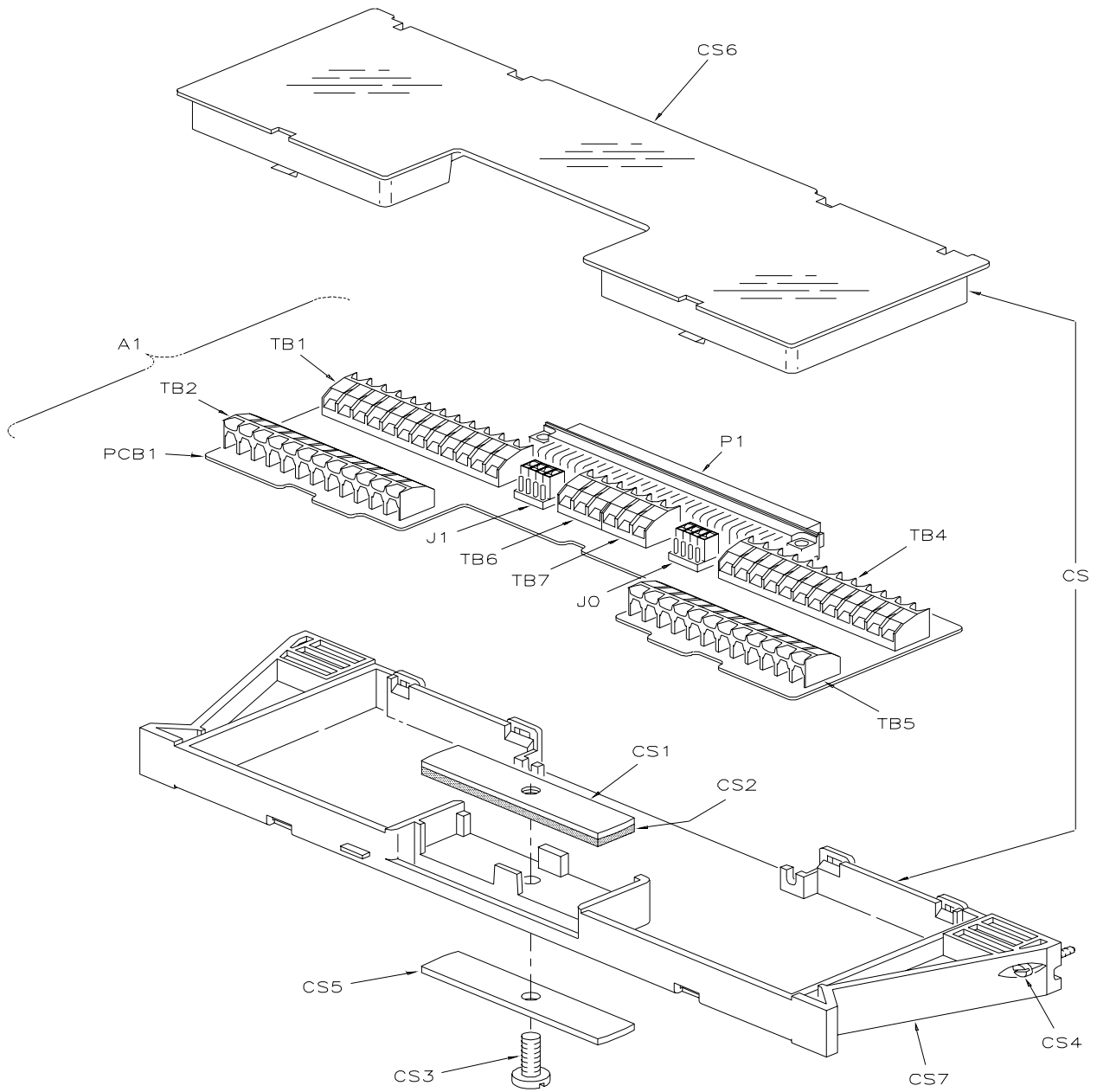

Figure B-3. E1355A/56A Terminal Module Mechanical Parts



Copyright © Agilent Technologies, Inc. 2005



E1345-90013